

# Development Workshop

on Building & Planning in the Third World

Box 133  
238 Davenport Road  
Toronto  
Ontario M5R 1J6  
Canada

BUILDERS TRAINING WORKSHOP

&

LITERACY CENTRE CONSTRUCTION

PROJECT

Chikal, NIGER 1980

© DEVELOPMENT WORKSHOP 1982

No part of this document nor the material it contains may be reproduced by any means without the prior permission of the copyright owner.

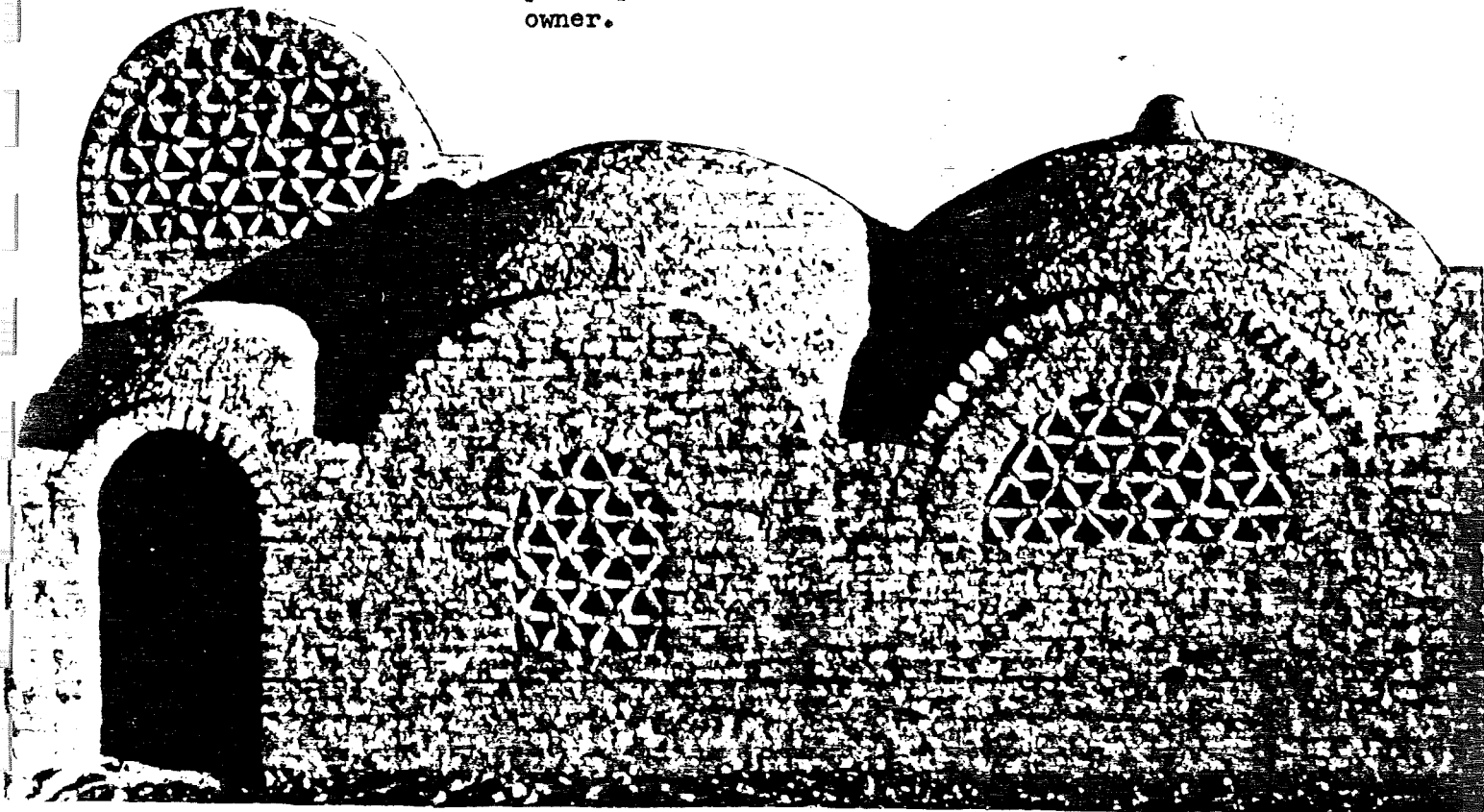

co-directors: FAROKH AFSHAR • ALLAN CAIN • MOHAMMAD REZA DARAIE • JOHN NORTON

Canadian Federal Incorporation Number 123277

CONTENTS

	Page
Acknowledgements	3
Introduction	4
I Research and Development	5
A. Mud Block Production	5
B. Soil Cement	17
C. Water Resistant Renders	18
D. Animal Traction	25
II Training Workshop	30
1. Laying Out	31
2. Footings and Foundations	32
3. Wall Building	33
4. Arches	34
5. Vaults	35
III Literacy Centre	
Finishes and Hardware	50
Conclusion	51
Appendices	
1. Evaluation Report Aug.82	
2. D.W. Block Ram	

ACKNOWLEDGEMENTS

The Chikal workshop was made possible by the excellent groundwork done by the Tapis Vert's staff.

Peter Tunley's energy, command of Hausa and involvement in the workshop process ensured its success.

Stan Zippan's prior survey identified the potentials of vault and dome building in the Chikal region and recommended the Development Workshop's involvement in introducing the technology. Thanks to M. Idrisa, Director of Project Tapis Vert for his interest and for the support he gave the programme.

In Chikal, Warren, Peter, Roy, Steve and Bernie all contributed their experience and ideas on the structuring and design of the workshop and building of the prototype.

Plans were discussed with the Chikal village elders who offered their support and donated a site for the Literacy Centre - pilot building. The Chikal people gave their curious though sceptical attention, which later gave way to enthusiasm when the project neared completion.

The team of village builders remain the key to the success of the workshop. They are the catalyst through which new ideas will reach the community at large.

Allan Cain  
for the  
Development Workshop  
Luanda 1982

## INTRODUCTION

In the autumn of 1980 the Development Workshop was asked by the Institute for the Study and Application of Integrated Development in Toronto to carry out a joint training and construction programme for the Project Tapis Vert (PTV) in Chikal, Niger.

Chikal is a small village region within the Sahel Zone. PTV is one of the projects involved in the fight against desertification on the southern margins of the Sahara.

The cutting of timber for traditional roofing is one of the factors contributing to the depletion of vegetation and resulting erosion and aridification in the Chikal region.

After a study trip in 1979, Architect Stan Zippan suggested the introduction of mud-brick vault and dome technology as a potential alternative roofing which eliminates the need for timber. He recommended the involvement of the Development Workshop who have experience working with these technologies for a number of years in the Middle East and North Africa. A training workshop was organised to transfer these technologies to the Chikal Region.

Allan Cain from the Development Workshop led the training workshop and carried out with PTV the pilot construction of a village-literacy centre in November and December of 1980.

The aims of the Chikal workshop were as follows:

- a. the training of a team of village builders in mud-brick vault and dome technology.
- b. Construction of a prototype community building "Literacy Centre" using this system illustrating some of the potentials of the vault and dome technology.
- c. Developing solutions to the problems of rain and weathering damage to mud structures.
- d. Making recommendations on mud-brick production.
- e. Developing improved building skills in the use of local materials.

## I. RESEARCH AND DEVELOPMENT

### A. MUD BLOCK PRODUCTION

Clay for mud brick making exists in good quantities near to the village in the "mar" (seasonal pond) just north of the project headquarters. The "mar" is replenished every rainy season with fine clay particles washed out of the neighbourhood's soils. Water with suspended fine particles collects in the low basin of the "mar" and slowly evaporates during the first few months of the dry season - October to January. Above all other factors this process sets the limits of the active building season in Chikal, since the "mar" not only provides clay for block making but also acts as a reservoir for water close to the village which is an essential component in the building process. When the "mar" begins to dry up as it does in late December, the housebuilder has to go further afield, often several kilometres to haul water back to the village in 200 litre drums. It happens that this season when water is available in the "mar" also corresponds to the cooler months when construction work is less strenuous.

It is paradoxical that the general depletion of the soils in the neighbourhood should have the advantageous side effect of providing an annual supply of good building clay. As the Tapis Vert's re-afforestation and soil stabilization projects begin to take effect the increased vegetation will reduce the rapid run off of water and soils will retain more of their fine particles. In this case clay building resources will have to be controlled as they will no doubt be more limited.

Another potential problem associated with the present uncontrolled excavation of clay for block making is the danger of penetrating the layered clay deposits which now act as a basin to hold the run off water. If pierced the water may seep away into the generally coarser soil strata below. Therefore shallow quarrying of clay would be advisable.

After an analysis of mud blocks made in Chikal a number of problems were noted:

- i. blocks were often of a poor quality and sometimes severely cracked;
- ii. blocks were irregular - distorted particularly on the bottom face;
- iii. blocks of various sizes ranging from 30 x 20 x 10 cm to 40 x 22 x 15 cm. Every builder or block maker used a different sized block mould.
- iv. relatively slow rate of block production.

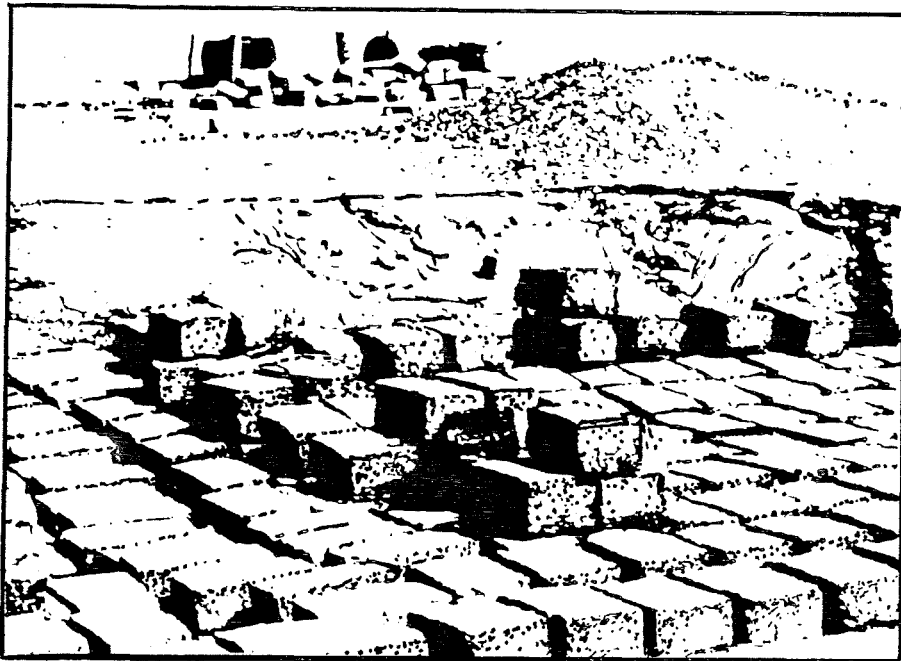

### Solutions Developed

1. Traditional blocks were made in Chikal by mixing "mar" clay with dung and straw - agricultural residue. While the organic matter tends to retard the rate of drying and hence reduce somewhat the cracking, severe cracking was still the rule. Cracking indicates the presence of too high a proportion of clay in the block mix. This can be partially alleviated by slowing the drying time by shading the drying area or covering the blocks with wet sacking. The best way of resolving the cracking problem however is to adjust the mixture of the blocks to reduce the clay content. This can be done by adding sand to the clay mix or by excavating soil from a different site which already contains optimum proportions of sand and clay (and the intermediate particles of "silt"). With this in mind soil samples were taken from various sites and a makeshift laboratory was set up in the Tapis Vert office to test the samples. Soil samples from four different sites are presented here:

- (A) "mar" black soil from excavation site;
- (B) termite mound near north of the block yard;
- (C) site of Literacy Centre within the village; and
- (D) west of the experimental agricultural plots.

The tests and visual observation indicate that the soils available in the Chikal area tend to be polarized, ie highly sandy on the one hand or rich in clay on the other. Therefore it is not feasible to re-locate the block making yard since a site having an optimum soil mix does not exist naturally. It is therefore recommended that sand should be transported to the existing yard to mix with the clay.

Reducing the quantity of clay in the block mix has the incidental effect of promoting the long term conservation of the clay resource.

The laboratory tests indicated that the quality of the mixture could be improved by an addition of one to two parts sand per three parts "mar" clay. Cracking and shrinking of blocks was substantially reduced when this improvement was implemented.

**Development Workshop**  
on Building & Planning in the Third World

SOIL ANALYSIS

LOCATION: Chikal, NIGER

SITE: Block Yard excavation site (A)

DATE: November 14, 1980

**Granulometric Chart**

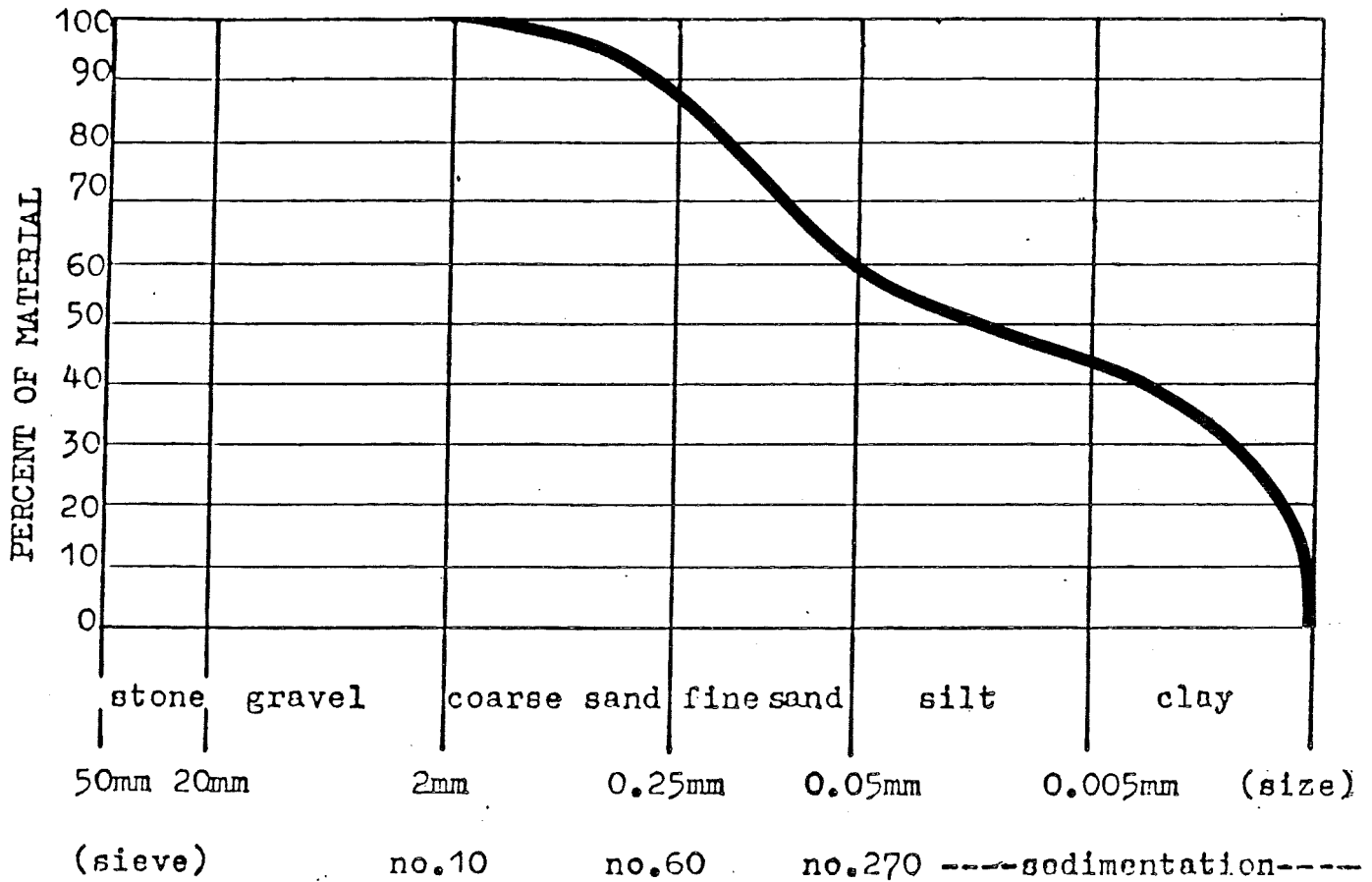

**Particle Gradation**

PARTICLE	mm SIZE	no. SIEVE	PER-CENT
Gravel	+2	10	0.0
Coarse Sand	+.25	60	41.0
Fine Sand	+.05	270	15.0
Silt	-.05	270	44.0
Clay	.005	sed.	

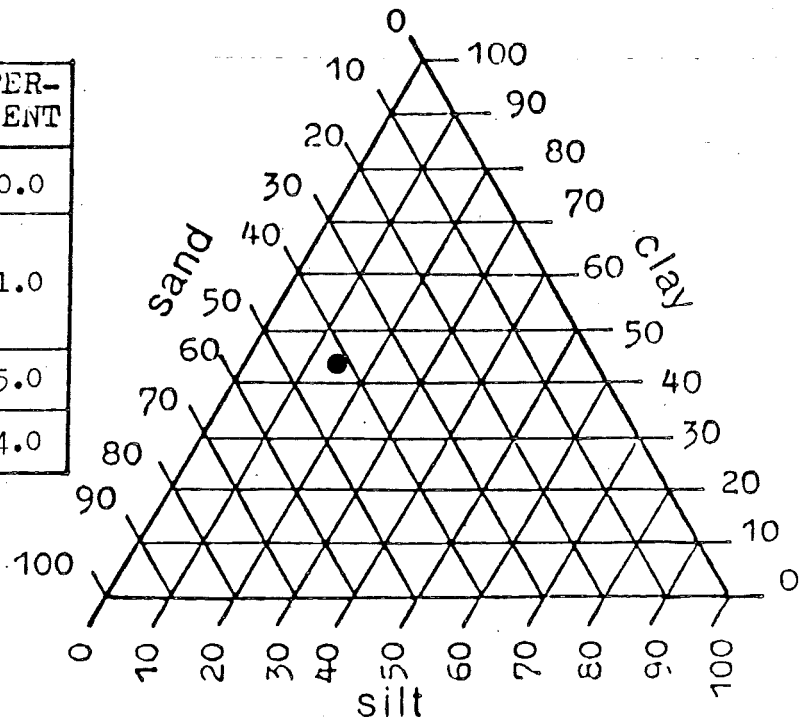

Soil Classification:

CLAY

Classification Chart

**Development Workshop**  
on Building & Planning in the Third World

SOIL ANALYSIS

LOCATION: Chikal, NIGER

SITE: Termite Mound north of block-yard (B)

DATE: November 14, 1980

**Granulometric Chart**

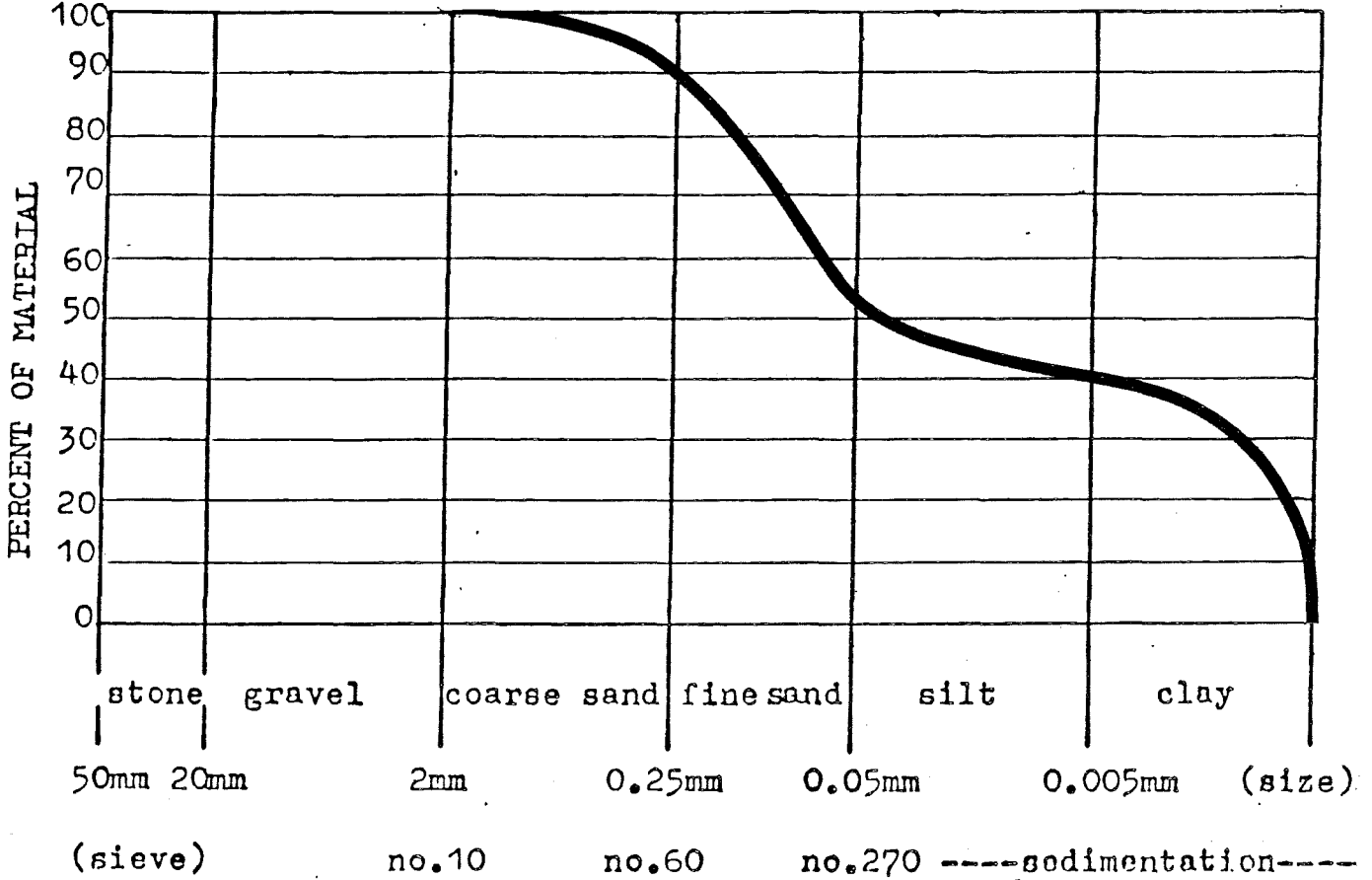

**Particle Gradation**

PARTICLE	mm SIZE	no. SIEVE	PER-CENT
Gravel	+2	10	0.0
Coarse Sand	+.25	60	49.0
Fine Sand	+.05	270	11.0
Silt	-.05	270	40.0
Clay	.005	sed.	

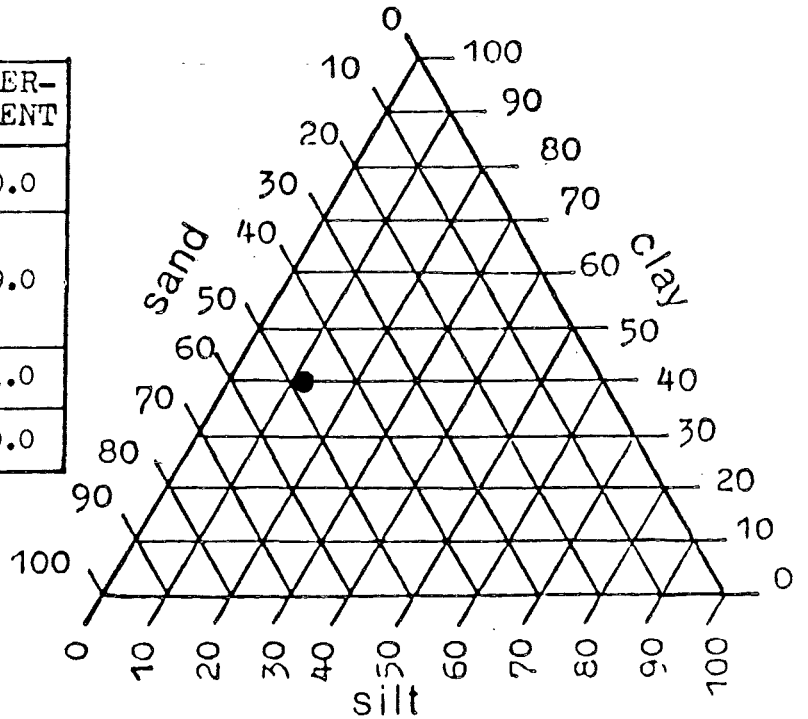

Soil Classification:

CLAY

**Classification Chart**

**Development Workshop**  
on Building & Planning in the Third World

SOIL ANALYSIS

LOCATION: Chikal, NIGER

SITE: Literacy Centre Site (C)

DATE: November 15, 1980

**Granulometric Chart**

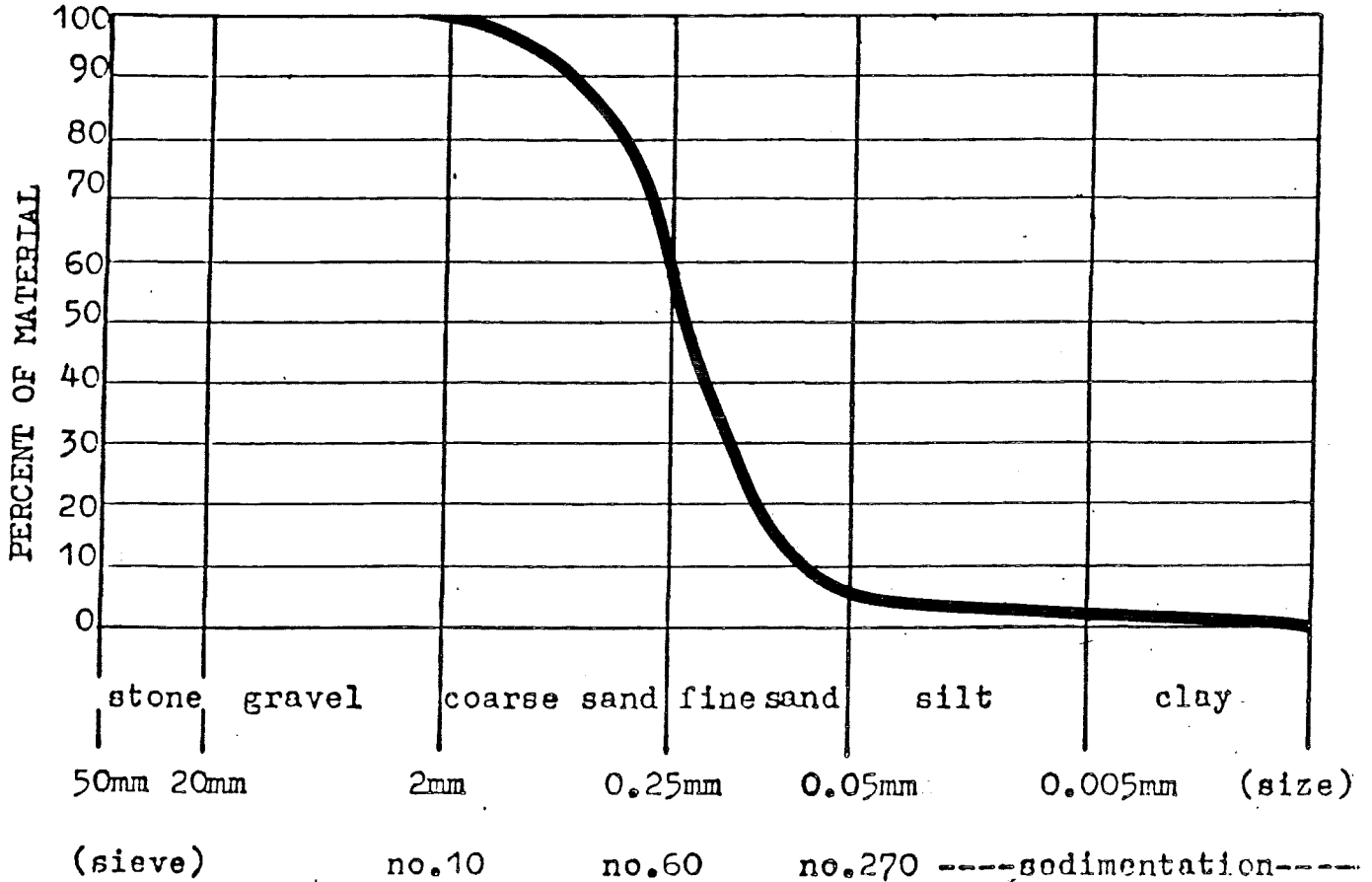

**Particle Gradation**

PARTICLE	mm SIZE	no. SIEVE	PER-CENT
Gravel	+2	10	0.0
Coarse Sand	+.25	60	95.0
Fine Sand	+.05	270	4.0
Silt	-.05	sed.	1.0
Clay	.005	sed.	1.0

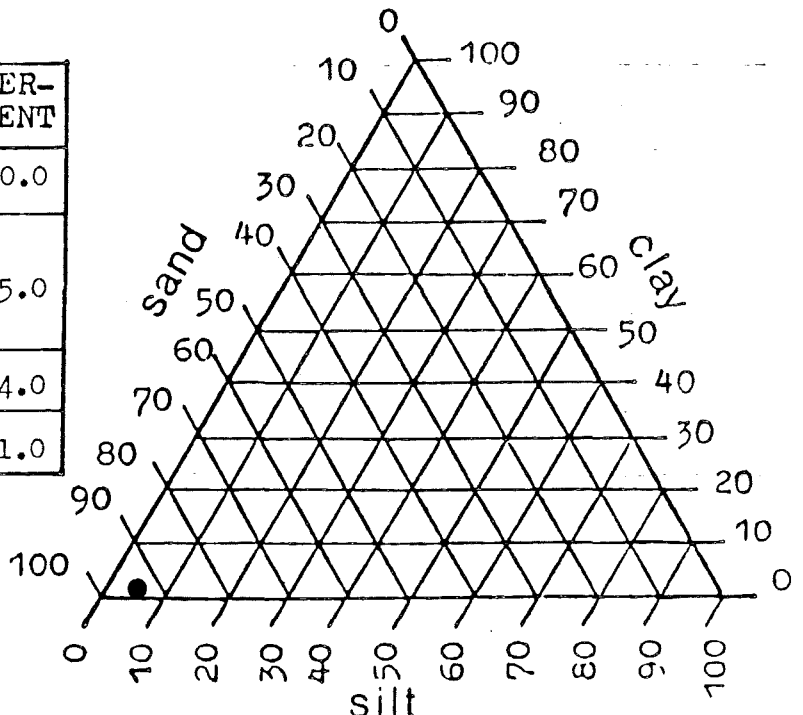

Soil Classification:

SAND

**Classification Chart**

**Development Workshop**  
on Building & Planning in the Third World

SOIL ANALYSIS

LOCATION: Chikal, NIGER

SITE: West of Agricultural Experimental Plot (D)

DATE: November 27, 1980

Granulometric Chart

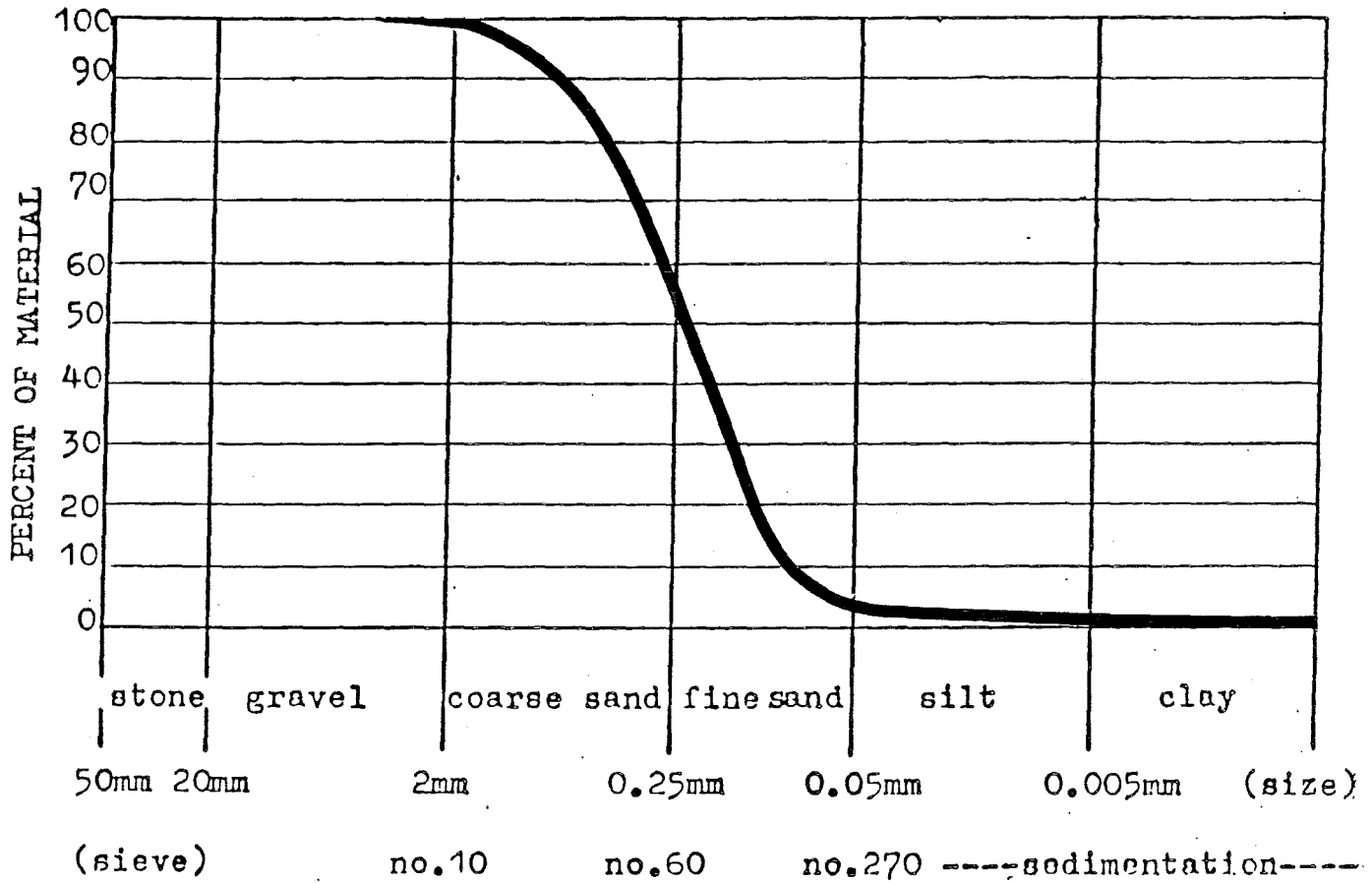

Particle Gradation

PARTICLE	mm SIZE	no. SIEVE	PER-CENT
Gravel	+2	10	0.0
Coarse Sand	+.25	60	97.5
Fine Sand	+.05	270	
Silt	-.05	270	1.5
Clay	.005	sed.	1.0

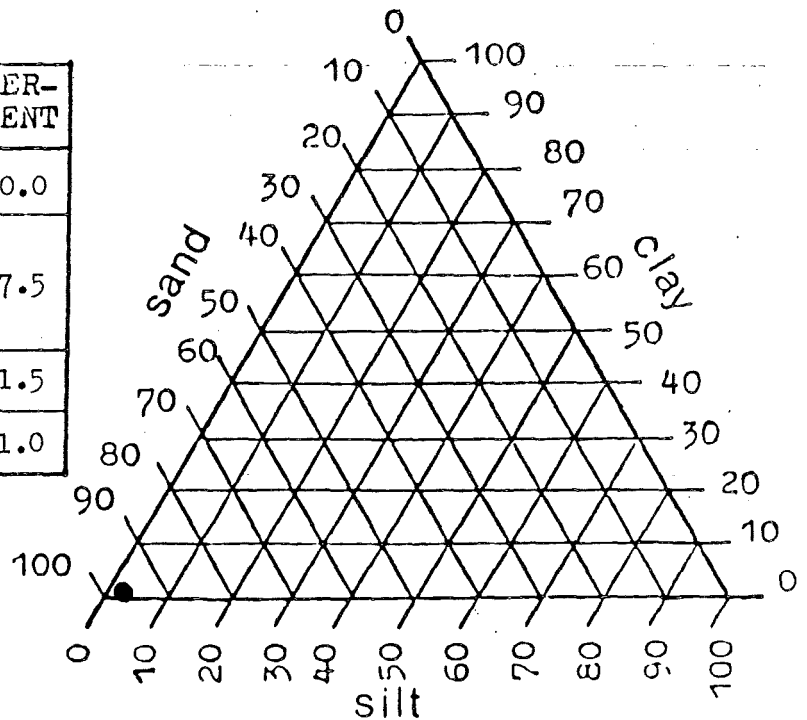

Soil Classification:

SAND

Classification Chart

2. The irregular and distorted form of many of the traditional blocks can be attributed to two causes:

- a. in the process of making a block mud lumps are drawn from the mixing pit and kneaded or rolled on the ground before being placed in the block form. The mud lumps pick up dust and dirt on their surfaces when in contact with the ground and when placed in the formwork these surfaces form dry creases or lines through the block which remain weak and can later form cracks or fracture lines. This problem can be simply resolved by carrying out the kneeding stage in a mason's pan, or on a board.

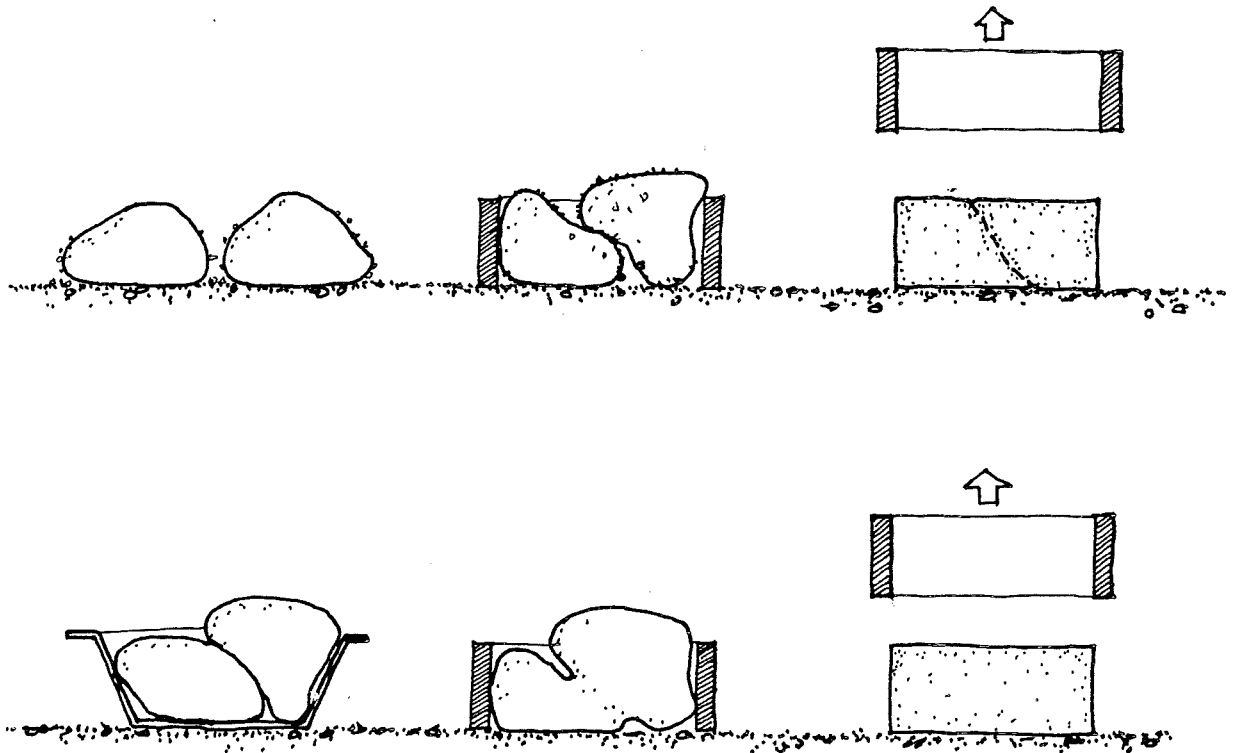

b. The second and more common problem of irregular blocks is caused by the fact that the wet blocks are laid directly on to the uneven earth surface of the production yard. The wet clay moistens the earth base and they dry together. Therefore when blocks are to be moved they pick up earth as well and are almost always misformed on at least one surface. Normally on the building site the mason wastes a great deal of time turning each block to make uniform surfaces before laying. If the yard floor is very irregular the whole block will slump into a form following the contours. The simplest solution to this problem is to spread a layer of "medium" sand evenly as a base for the block yard floor. The wet block will only pick up a thin even layer of sand while drying and this easily brushes off later.

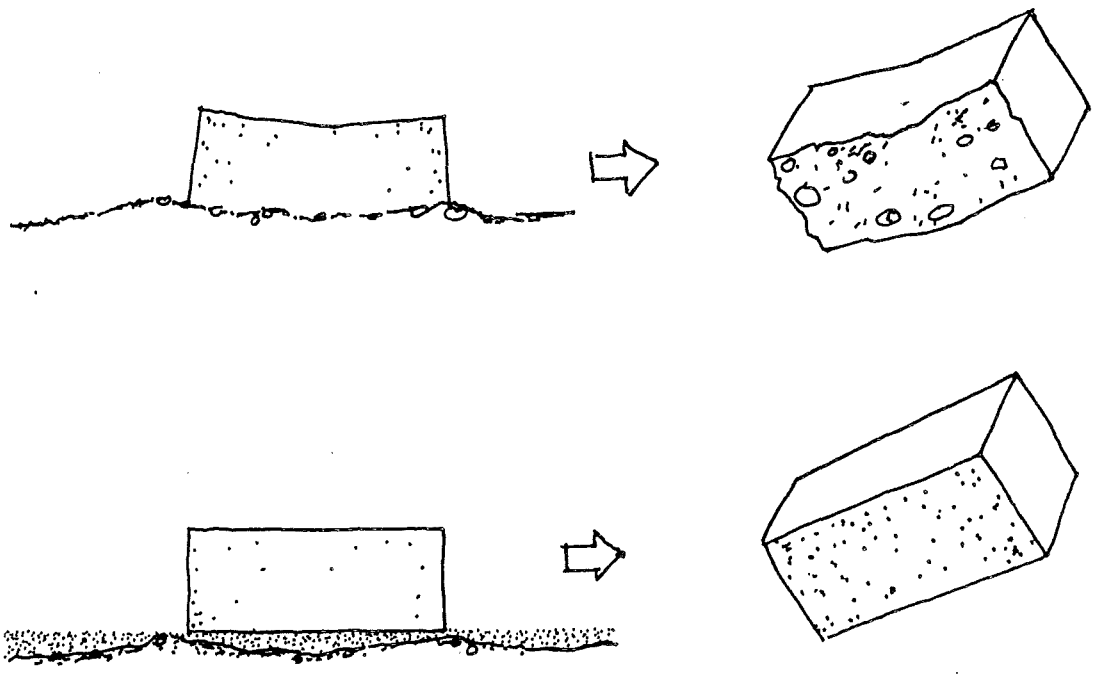

3. The sizes of blocks traditionally vary considerably. No two moulds were the same size. This lack of coordination of block size meant that in building, bonding of corners and walls of more than one brick thick was exceedingly difficult. Poor bonding results in overall structural weakness.

A new modular size block was introduced, approximately the traditional average in dimensions and weight. The dimensions of the new block are 40 x 19 x 10cm and the weight is 13 kg. The modular block can easily be bonded in many ways and can be coordinated to standardized wall dimensions.

Wall Block

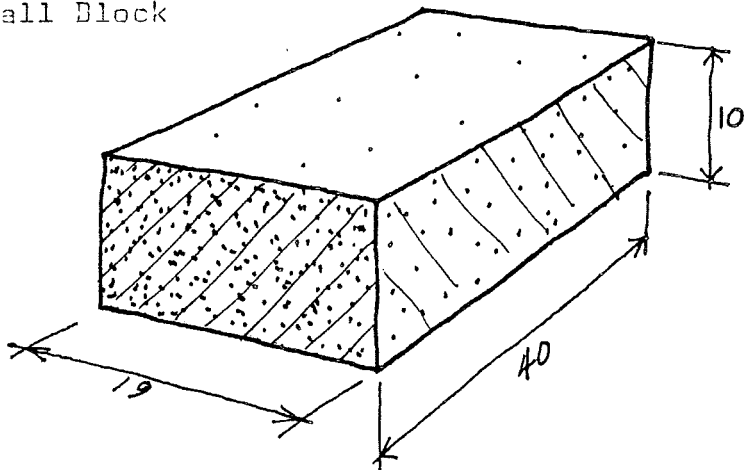

Roof Brick

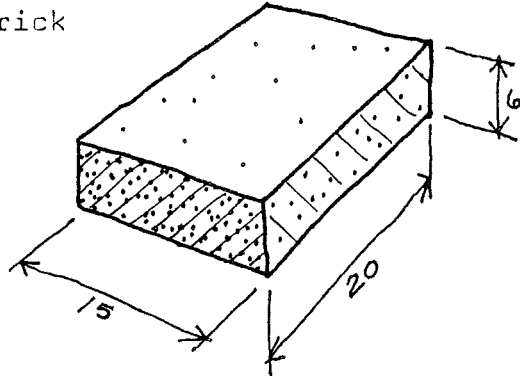

4. The rate of production of blocks was noted to be relatively slow and day to day production, irregular. Only about 250 to 300 blocks were being made per day. Labour was continually being shifted and tasks were unclear. Improved production yard management and increased specialisation of activities can increase the production substantially without actually increasing labour input. In fact rationalising the production yard organisation will reduce overall work energy.

A control group of six workers were chosen to operate together as a team. Tasks were defined: two people were digging clay for the next day's brick making, two people mixed the already prepared mud and delivered it to the block maker, one person made the blocks using a hand mould and one helper turned the bricks and stacked them and helped in digging, delivering straw and loading blocks on to the delivery cart. Activities could be periodically rotated so that the heavier work would be shared evenly and when one team member found himself free of his task he could assist the others wherever he was most needed.

The control group was monitored for a six hour period of production of blocks (40 x 19 x 10 cm). The results are shown in the following chart.

It should be noted in conclusion to the discussion on improved mud block making that none of the innovations involve increasing capital expenditure on production. Sand is the only material added and this is available close to the yard. Rationalised organisation will reduce the overall costs and increase the quality of the product.

Pilot Block Making Schedule

Time hours	Inter- val	Bricks Produced	Accumulated Total	Rate per Hour
8.00 10.00	2.00	240	240	120
10.00 10.20	0.20	rest break	240	0
10.20 12.20	2.00	184	424	92
12.20 14.00	1.40	146	560	87
8.00 14.00	6.00	560	-	93

## B. SOIL CEMENT

While mud block provides an excellent general building material in Chikal there are some specific requirements for materials having greater water resistance. One of these problems is building foundations and footings for the bases of walls. Although it is a common fallacy in Chikal that footings are a waste of time and money, they remain one of the few low cost investments that can substantially increase a building's life. One can note in many buildings in Chikal that bases to walls have been severely eroded by rain and runoff and cracks have sometimes formed where there has been movement. In spite of this it is realised that "stable wall footings" will probably be one of the last "innovations" to be accepted into the local building vocabulary.

When cement is available, even in limited quantities it can be used to stabilize soil blocks for footings. A series of "test blocks" were made on the Literacy Centre building site using soil represented in chart (C). Soil cement mixes were made ranging between 4% and 10%. It was found that 5% cement content was suitable for stabilizing the sandy soil but for load-bearing footing use between 7% and 8% should be recommended.

Local lateritic rock was collected from the base of the nearby "Doutchi" escarpment and used set in soil cement mortar to provide an excellent foundation material.

In summary, the above building practice is generally recommended, but particularly for vault and dome buildings. Vault structures do not accept movement within supporting walls. Development Workshop has carried out considerable research on problems of structural safety in these kinds of buildings and have found stable foundations and footings to be essential. (Ref 1)

C. WATER RESISTANT RENDERS FOR MUD WALLS

The application of water resistant renders to the exterior walls and roofs of traditional mud buildings will greatly extend their usable lives. Normally after a severe rainy season walls, particularly those directly exposed to rain bearing winds (east) should be re-rendered. The traditional render is mud mixed with a high proportion of dung and organic fibre such as straw. Re-rendering is often neglected, particularly on community buildings which are not the responsibility of an individual householder and building structures can rapidly deteriorate. Improved renders with longer life spans need to be developed for these cases.

Tests were carried out to develop suitable wall renders for mud building in Chikal. Soil cement mixtures were tested but it must be understood that access to cement by the general population is limited by cost and transport problems. A search was made for local materials which could be used for water-proof rendering. Three possibilities were tested:

- i. earth from termite mounds;
- ii. white crystalline deposits excavated near the "Doutchi" thought to be gypsum deposits;
- iii. acacia bean pods.
- iv. In addition soil cement renders were tested along with unstabilized mud plaster.

i. Termite mounds are known to stand up well throughout the rainy season and in other parts of Africa are excavated to provide earth for building purposes. It is commonly believed that this material has water resistant properties. Simple laboratory tests were carried out on the termite mound material to assess its properties. Results of the granulometric analysis can be found in chart (B). Additional salinity tests indicated that:

- a. the material contained 0.4% dissolved salts;
- b. the conductivity of the material mixed one part to four parts water was 2000<sup>m</sup> while tap water alone was 520<sup>m</sup>. \*

Water submersion tests were also made to compare the termite mound material (sample B) against soil samples collected nearby (sample A). A dry lump from each sample about 20 mm in diameter was each placed in a beaker of water and the rates of dissolution were observed. The clay lump (A) initially broke down slowly then swelled up and the action accelerated. The sample (A) had disintegrated completely in 5 minutes. The termite material (B) immediately began to break down then the action slowed with complete disintegration in 7½ minutes.

It can be concluded that the termite soil tested was marginally more water resistant than the clay sample but not significantly so.

The termite mound material may have a reputation as a good building material because termites tend to excavate clay deposits which may occur in strata well below ground level. They therefore bring clay to the surface where it is made more accessible for building purposes in areas where soils may otherwise appear to be too sandy for good block making or rendering. Further laboratory tests are being undertaken by Development Workshop to explore this material in greater detail, but at this point we cannot say conclusively that the material has properties significantly superior to normal clay soil.

---

\* Test apparatus "Salinity Conductivity Meter" No 33 YSI (Yellow Springs Inst. Co.)

ii. Gypsum is a very useful natural building resource because of its moderately effective water resistant properties and its relative ease of manufacture. The raw material often occurs in crystalline form and needs to be burned only at low temperatures to become a usable building product. White crystalline deposits suspected to be raw gypsum were collected near the "Doutchi" escarpment and tested. The samples were heated to a temperature above which normally would be necessary to cause the molecular transformation of the inert crystal to active gypsum (ie removal of bonded water molecules). Water was then added to the sample to make a paste (to rehydrate the "gypsum"). The sample was rolled into a small ball and air dried. After several days the ball was immersed in water. Rehydrated gypsum will hold its shape in water, but the test sample completely disintegrated. We must therefore conclude that gypsum was not present in the sample which most probably consisted of crystalline salts or minerals that had leached out of the neighbouring soils.

iii. Acacia Render

Several kilogrammes of acacia bean pods were collected to be used in the experiments. Acacia pods can be purchased in the local markets, where they are sold in small amounts to be used as herbal/medical teas. Acacia tea is known to alleviate some stomach complaints. Acacia is also used in limited quantities in traditional leather tanning. Large quantities can be collected during the winter season after the fruit pods have begun to dry on the trees. Acacia is one of the varieties of trees planted in Tapis Vert's re-forestation programme. A good supply of acacia beans should be available in the future.

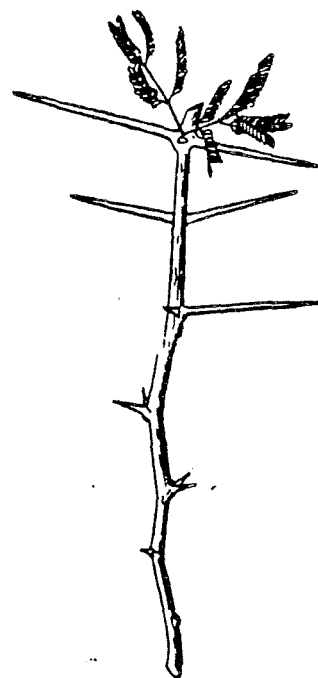

*Acacia scorpioides* (L.) var. *adstringens* Bak.

SYNONYM: *Acacia adansonii* Guill. & Perr.

FRENCH	gonakier	DJERMA	bani
CHAD ARABIC	sunta, charat, senet, sunt	FULANI	gaudi
BAMBARA	barane	HAUSA	bagarua
	dlabe	KANOURI	kangar
	bolna	MORE	kissau
			perananga

Found in highlands, in drier environments

Pods need to be dried for several days on screen-mesh racks under direct sunlight. The dry pods should then be pulverized into a powder using a traditional mortar and pestel (as used for grinding millet).

Characteristics of Acacia powder:

The powdered acacia pods have a "flaky" consistency. Dust from the acacia is acrid and irritates the nose. 1000 ml sample has a mass of 534.5 grammes. 1000 ml dry sample displaces 460 cc of water. Therefore Acacia powder has a density of 1.16.

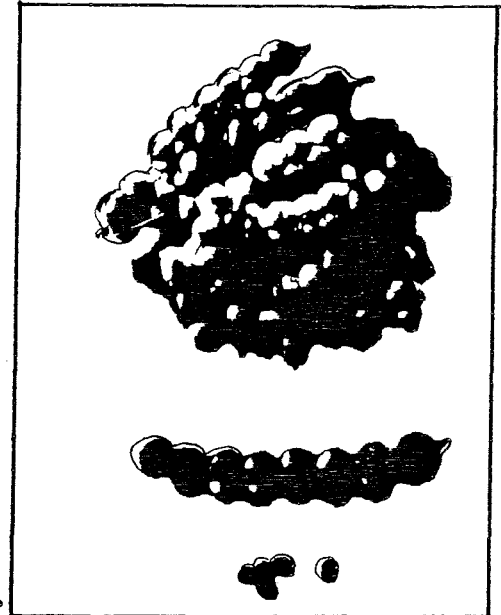

To prepare the acacia powder for building use, it is first mixed with water. 1000 ml are mixed thoroughly in 5 litres of water and allowed to stand for three days. The solution should be stirred two or three times a day.

After three days the liquid is passed through a seive. The residue is retained and soaked again in water to extract the remaining substances.

Soil is prepared by mixing three parts sandy soil (sample C) with two parts clay soil (sample A). The soil must pass through a 5 mm seive.

The render plaster is prepared by mixing thoroughly one part acacia liquid solution with three parts sand-clay soil.

The mud wall to be rendered is first brushed to remove loose material and dust and then lightly dampened with water. The acacia soil mortar is then trowelled on so that the minimum thickness of the mortar is 5 mm. It was noted that the mortar had a slightly sticky consistency.

The wet render had a redish-grey colour.

iv. Soil Cement Render

Cement has been widely used as a rendering material for mud walls with varying degrees of success. Although cement provides a hard water resistant surface against weathering it normally does not bond readily with the mud blocks it is protecting.

Different rates of thermal and moisture expansion between cement and mud sometimes cause small movements and shear at the point of contact between the two materials. This causes the render to separate from the wall or crack. Once water is able to penetrate behind the cement facade erosion can be rapid and the render can peel away.

A solution to this problem, is the use of soil cement as a render. Soil cement has a coefficient of thermal (and moisture) expansion much closer to the mud wall and therefore bonds more readily with the wall's surface. In our experiments in Chikal we used a 10% cement/soil mix. The soil used was a mixture of three parts sandy soil (sample B) and two parts clay soil (sample A). The soil passed through a 5 mm seive. The dry ingredients were mixed thoroughly and then mixed with one part water to three parts dry soil/cement.

The render mortar is then trowelled on to a mud wall (pre-prepared as in section (iii)) to a minimum thickness of 5 mm.

v. Sand-Clay Render

A sand-clay render without stabilizers was prepared as a control sample to be used as a comparison with the other renders. This render used the same 3:2 sandy/clayey soil mix as used in the previous examples and was similarly mixed with water in a 3:1 ratio. It was trowelled on to a pre-prepared wall to a minimum depth of 5 mm as well.

### Render Comparison

Seven wall areas were prepared each with a different surface render or treatment.

1. Acacia render as described in section (iii).
2. Acacia liquid painted as a brushed-on coat over (1).
3. Soil cement 10% as described in section (iv), trowelled to a smooth finish.
4. Soil cement 10% left as a rough surface.
5. Sand-clay render described in section (v).
6. Sand-clay render as (5) painted with acacia liquid solution.
7. Rough mud wall painted with acacia liquid solution.



### Conclusion

These preliminary tests indicate that the acacia render significantly improves the water resistant characteristics of mud wall renders. It should be noted that the acacia rendered wall stood up to 17 cycles of spraying before being significantly eroded while the sand-clay render showed considerable damage after only 5 spray cycles. This represents an almost  $3\frac{1}{2}$  times increase in the expected life of an acacia render over a mud render. We would therefore recommend that the acacia render be employed on some pilot buildings to be tested over several rainy seasons.

The Development Workshop is continuing laboratory research and practical development of the acacia render, since we feel that the material has a potential use in areas where cement is not available.

#### D. ANIMAL TRACTION EXPERIMENTS

The traditional methods of transporting materials in the Chikal region range from the use of human energy using head pans or shoulder yokes, to animal energy using the backs of donkeys and camels. These traditional methods are not only burdensome but are inefficient uses of human potential and animal energy. Non-indigenous means of transport now growing in use are animal carts of various types and motor vehicles.

Improving the efficiency of animal traction by the use of better carts and hauling devices is an important factor in Niger's rural development. The high cost of combustible fuels ensures that the option of animal traction remains most economical.

In the course of the training workshop, mud block production and the construction of the Literacy Centre a variety of methods for transporting materials were employed. An economic analysis of each system was made and the systems compared.

The animal traction experiments illustrate the relative economic advantage of using animal drawn carts over motorized vehicles particularly in short hauling situations. It can be seen that as distances increase and the actual moving time becomes significantly greater than the loading and unloading time (ie bring cement from Filingue) motorized transport becomes more expedient, though not necessarily cheaper.

In comparing the two types of animal traction it becomes clear that in economic terms the donkey and small cart performs better than the larger cart with two oxen. The initial capital outlay is less than 30% at government prices. It appears in practice that the single donkey cart can transport more blocks in a day than the larger two ox cart.



ECONOMIC COMPARISON - CAPITAL COSTS (1980)

Means of Transport	Cost C F A	Source	Working Life years	Comment
Ox Cart (cart only)	45,000	co-op		strong type
	90,000	market		
Ox Cart & Plow	225,000	co-op (govt)		repayment over 4 years
Ox	± 55,000	market	4-6	
Donkey cart (cart only)	28,000	co-op	short	weak construc- tion
	63,000	Catholic mission	long	all metal, low bed
Donkey	± 15,000	market	4	
Donkey & cart	60,000	co-op		repayment over 4 years
Pick-up Truck	±5,000,000	market	2-4	estimate 1981

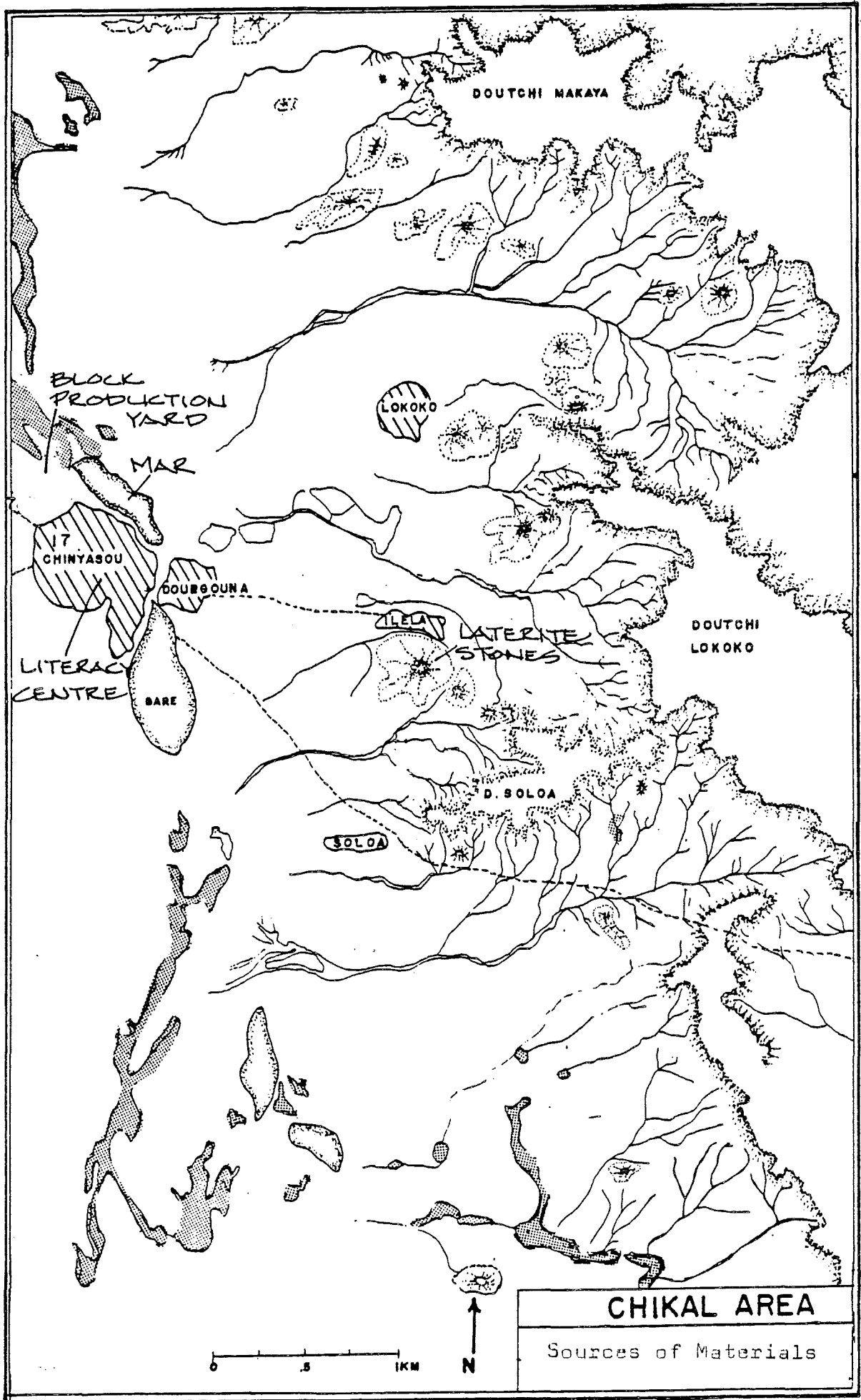

Traction Comparison

Load vs Time

Type of Transport	Type of Load	Weight Kg.	Distance Metres	Trips per Day	Cost per Trip CFA	Comments
2 OXEN with large flat-bed cart	70 large blocks 40x19x10	910	500 one way	5-6	250 to 300	optimum load can carry continuously with normal stops for loading
	100 large blocks 40x19x10	1,300	500			can carry with strain over short duration
	240 small bricks 20x15x6	720	500			
1 DONKEY with small flat-bed cart	32 large blocks 40x19x10	416	500	10	150	optimum load can carry continuously with normal loading stops
	48 large blocks 40x19x10	625	500			can carry with strain over short duration
	90 small bricks 20x15x6	270				
1 DONKEY with small semi-open metal cart 2 workers	0.4 cu.m. + 45 laterite stones 25cm.diam.	456	2,000	3		30 min. outward trip 1 hr. collecting & loading 40 min. inward trip
LANDROVER	80 blocks 40x19x10	1,040	500			
LANDROVER 2 workers 1 driver	0.93cu.m. + 100 laterite stones 25cm.diam.	1,050	2,000	6-7		

Note: In each case loads were transported over sandy tracks. In cases where it is noted that loads are heavy and can be pulled "with strain", animals had trouble pulling through patches of loose sand on the track.

## II TRAINING WORKSHOP

A group of seven village builders and building assistants from the different villages in the Chikal region was selected to take part in the training programme. The trainees had a variety of different levels of skill. Some were experienced only in traditional mud-lump wall construction while others had a knowledge of some elements of modern building practice such as how to use a level and plumb line. The majority of the group was illiterate though one or two participants had some rudimentary reading skills.

The principle of the 'Workshop' training technique is the sharing of knowledge and experience. Therefore a participant with greater skills in some areas is encouraged to bring the others up to his level. It was explained in the beginning that the vault and dome construction system which was to be the focus of the programme was developed and practised by people in Iran, Egypt and other countries who lived in villages very similar to those in the Chikal region with all of the same problems of development. These people (in the Middle East) had found an effective way of solving their building problems without having to cut scarce timber.

The workshop leader acted to assist in the transfer of the "ideas" and it remained for the participants to use, develop or reject them.

Within this transfer process we were able to inject some of the improvements that Development Workshop has made on the building systems.

Although the focus of the workshop was to introduce some of the basic principles of vault and dome building an important second aim was the improvement of general building skills of all the participants. The two aims are actually inseparable because the building of masonry shell roofing pre-supposes a good knowledge of basic masonry construction. Mud block and brick was a relatively new material for those builders whose speciality was mud-lump walling. In fact all of the builders had much to learn about basic masonry building practice, such as corner bonding, levelling and the handling of materials.

Although the vault and dome system demands a certain level of precision in construction, these principles can be easily mastered by the Chikal builders. Simple techniques have been adapted from other rural building traditions and therefore do not require literacy skills.

The workshop had two parts, firstly the demonstration of individual elements of building from footings, to walls and roofing and practice on a small scale structure; secondly construction of a full scale pilot building (Literacy Centre) to consolidate new skills.

1. Laying Out.

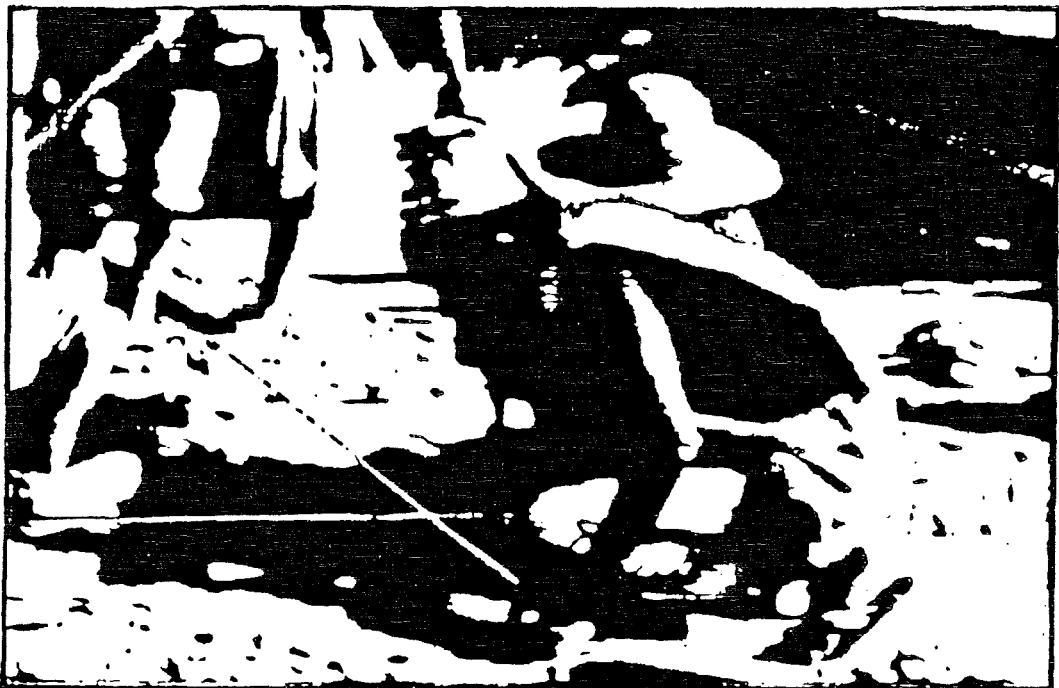

## 2. Footings and Foundations:

The importance of strong footings made of water resistant materials was emphasized, particularly for buildings with vault and dome roofing which cannot tolerate movement in supporting walls. The traditional practice of digging a very shallow trench to be levelled with a single course of mud brick is insufficient. In fact this practice should be discouraged since when wet the clay of the mud block will expand to a greater extent than the normally sandy soil and result in wall movement. In this case it is better to do away with the footing altogether, rather than have mud-blocks buried below ground surface level where their contact with moisture is inevitable.

Good foundations and footings can be made with stone, lime/clay soil and soil-cement. The principle must be to protect the mud-block walls from all contact with water:

- i. rising through capillary action from the soil; and
- ii. water washing away the bases of the walls during rain storms.



### 3. Wall Building:

Some of the builder trainees had had little experience with mud block buildings and the basic principles of bonding were somewhat new to everyone. The use of simple tools such as the spirit level, to maintain horizontal courses and the string to maintain a uniform level were introduced.

The plumb line was demonstrated for maintaining verticle walls. Bonding: Bonding of blocks to make walls of varying thickness was demonstrated. Because of the thrusts that vaults and domes exert on supporting walls, wall dimensions must vary in thickness accordingly. Bonding of blocks becomes complicated when building corners of walls more than one block thick.

In general bonding must ensure that blocks overlap sufficiently to avoid continuous lines of vertical joints which can form weak seams or cracks in walls that must resist the horizontal thrusts of the shell roof forms.

Mortar Joints: The mortar used in building mud walls is the same wet mixture as that used to make the blocks. This is unlike most other masonry structures, whose mortar joints are of different materials from the actual building material. Mud blocks and mud mortar can potentially form a strong homogeneous mass when dry to resist internal

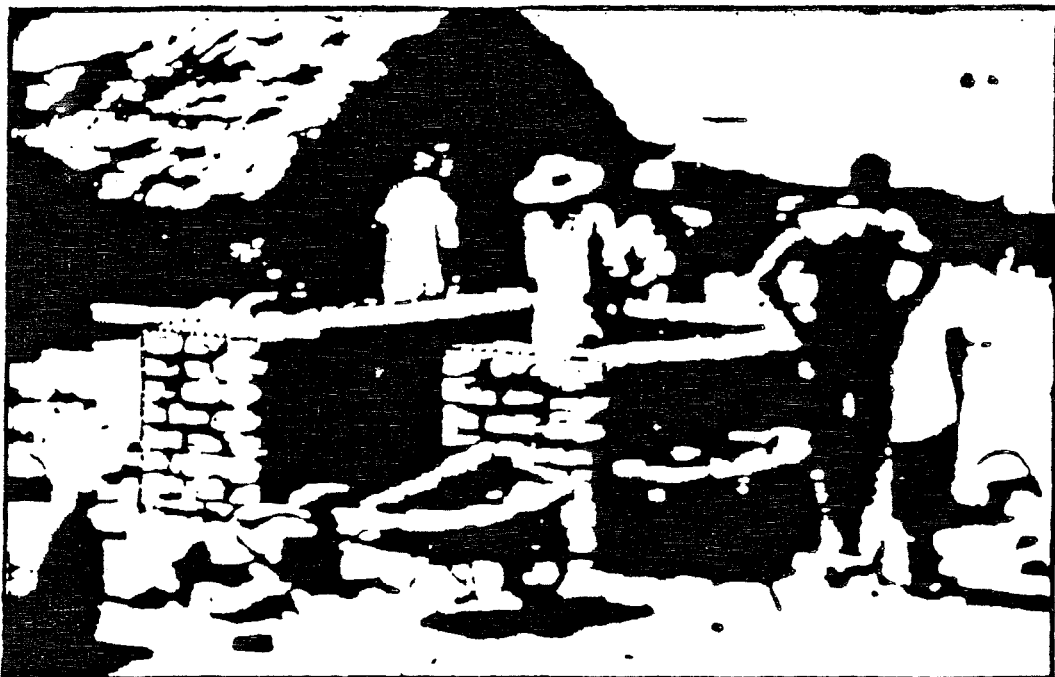

stresses. In order to ensure a strong bond, the surfaces of the mud blocks should be slightly dampened before the mortar is applied to them.

This principle was demonstrated many times to the builder trainees as a simple way to greatly increase the strength of mud block walls with the addition of small quantities of water.

It is common in laying masonry walls to omit the filling of vertical joints with mortar. Properly filled vertical joints increase the overall strength of walls. This is a particularly important factor in walls of vault and dome structures because the horizontal forces tend to produce vertical cracking at weak points.

#### 4. Arches - Door and Window Openings:

The traditional practice of building door and window openings is to use branches to form lintels or reinforced mud arches. Not only does this practice consume timber but after a very short time all timber buried in mud walls is eaten by termites, thus weakening the opening. In the case of arches built in this manner the timber nearly acts as a formwork which is eaten away rather than removed, leaving a curved form which remains structural.

Mud block arches are much stronger forms than the above mentioned and do not consume timber.

Two systems were demonstrated for building mud block arches, one using a formwork made of dry blocks without mortar and a second system using re-usable timber formwork. The first solution is less expensive in materials though more time consuming. The form-making materials can be re-used in further wall building. The second solution involved building formwork out of sheets of used plywood. The form after use can be re-used many times to produce standard sized door and window openings.

## 5. Vault and Dome Roofing

Out of the wide range of available vault and dome roofing forms, two were selected for introduction in the workshop. This type of 'shell' roofing can cover almost any configuration of space or room layout. However the two forms chosen: the 'pendentive dome' and the 'catenary vault' are limited to roofing square rooms or simple rectangles. At this stage it was felt that there was insufficient time to train the builders in other forms.

The pendentive dome is geometrically a 'segmented hemisphere' built on a room having a square floor plan. The complete geometry of the roof is determined by a length of string anchored to a post located at the geometric centre of the room at a point normally about shoulder height. In the practice structure the 'spring point' was located much lower to save building materials.



The string is used to trace out 'arcs' which are built up vertically from the spring point levels on the walls. These four arcs form the base on which the dome is constructed.

The curved pendentives are first built up with courses gradually sloping in enclosing the circle of the dome. The courses of brick in the dome proper are built in horizontal rings. Each ring becomes a compressive element until the dome is completed and the mortar dries. The dome then begins to act as a shell in structural terms.

As soon as the last brick is in place the dome can support the load of several people.

Vault and dome bricks differ in size from the larger blocks used in wall building. Roof bricks have dimensions of 20 x 15 x 6 cm and are of the same material as the walls. Weight 3.0 kg.

### Vaults:

The Catinary Vault was selected as the second shell roof form to be introduced into the workshop because of its structural safety (ie it will accept a small degree of error when constructed by builders with little experience). While other vault types provide more flexibility in height, span and shape the catinary vault can be used only to roof over simple rectangular rooms.

The catinary is the form taken by a chain, suspended from both ends and allowed to hang freely. The catinary curve is a perfect tensile form since each link of a chain responds to gravity separately and can only transmit tension forces to the other links. If one can imagine the catinary curve frozen and inverted it will form a perfect compressive curve. Since mud materials can only transmit compressive forces easily and are relatively weak in tension, bending and shear the inverted catinary becomes an optimum form for mud brick shell forms such as vaults.

The vault is built without formwork in the Nubian method of using sloping brick courses which lean against an end wall which supports the weight of the vault until the mortar dries.

Unlike the dome construction the vault building is not assisted by geometrical formula pre-determined by a string tied to a focus and tracing out the form to be built. The vault builder has only the shape of the inverted catinary traced on the end supporting wall. The shape of the vault must be maintained by the builder by periodically eye-levelling the structure to ensure consistency. This skill comes only with experience. Non-structural template guides can be used but these are large, awkward and time consuming.

The training of builders in vault building began with the construction of small one metre vaults. In stages the size was increased to two metres. Vaults were constructed, knocked down and re-built a number of times as each builder attempted to master the form. During the workshop the trainees received a good basis and understood the process of building vaults but by the end of the programme they still needed more practice before they could tackle a vault building project unsupervised. It was advised they they continue such practice and eventually increase the span size to three metres which is sufficient for many domestic scale buildings.

The dome building technology was mastered much more easily and it was felt that after practice building small domes of two metres to 2.5 metres the builders could graduate to full scale four metre domes with supervision.

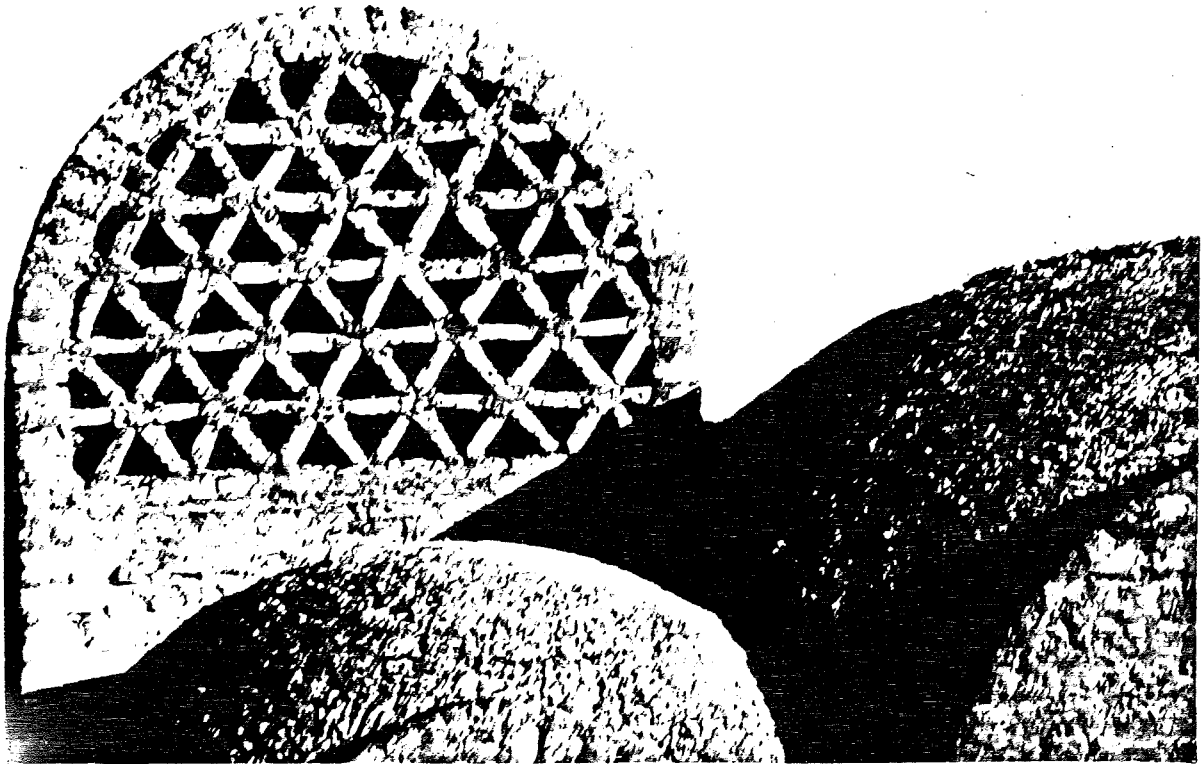

III LITERACY CENTRE

Community buildings such as schools and clinics are important focal points in the village context. Too often these buildings are means of introducing inappropriate building images from outside. Expensive materials such as concrete and steel become associated through such buildings with modernity and progress. Too often standardized public building projects, designed to be used throughout the country are in practice unsuited to the needs and environments of the communities where they are built. The Literacy Centre project was designed with these considerations in mind. It was to be built by the village builders

The project was discussed in detail with the village elders in order to enlist their support and interest. The building site was located within the village close to one of the principal water points. Every attempt was made to integrate the project into the village community so that the new ideas that it introduced became accessible to the population. It was hoped that this community building would present images and technological methods appropriate to the local conditions.

P.T.V.  
Hq

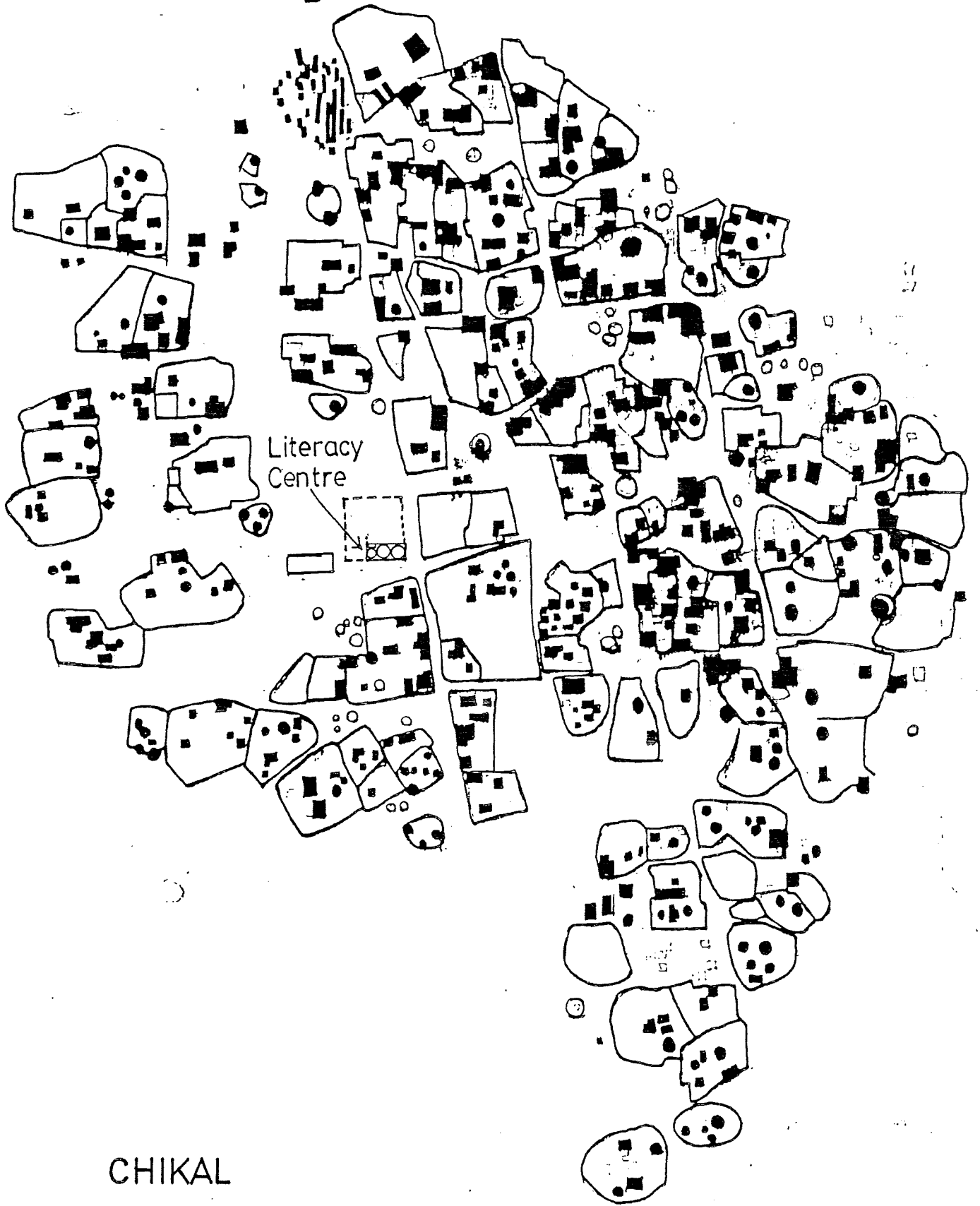

CHIKAL

The building was built without stylization as it was felt that such elements must be left to the local builders. Each building element introduced had a purely functional reason and form. Thus the roof's vaults and domes had clear curved forms but only because this is the most efficient structure for spanning in mud brick. Lattice windows were introduced because they cut down glare, provide essential shading and security functions and are an inexpensive method of doing this. Their geometrical configuration is one of the simplest to build.

A wind-catcher was introduced because it was felt that this low-energy method for cooling and removing dust from the air would have a great potential in the Chikal environment.

The particular design of the Literacy Centre building was not only based on functional considerations but with the training of the building team in mind. Some of the potentials of the new technology were demonstrated; ie how to increase room size by using alcoves within the walls; how to join two domed rooms together, using arches, how to link spaces of different sizes and the corresponding effect on roof heights and doorway clearances etc. The logic of some of these design considerations can really only be demonstrated to the builder in such a pilot building.

In general it was felt that the pilot building should present to the trainees a simplified basic "vocabulary" of mud brick and vault and dome technology. It must remain for the builder and his clients in the village community to decide what they feel is useful and how they wish to adapt and re-arrange the basic elements.

The technologies introduced during the training session were utilised albeit on a larger scale in the Literacy Centre project.

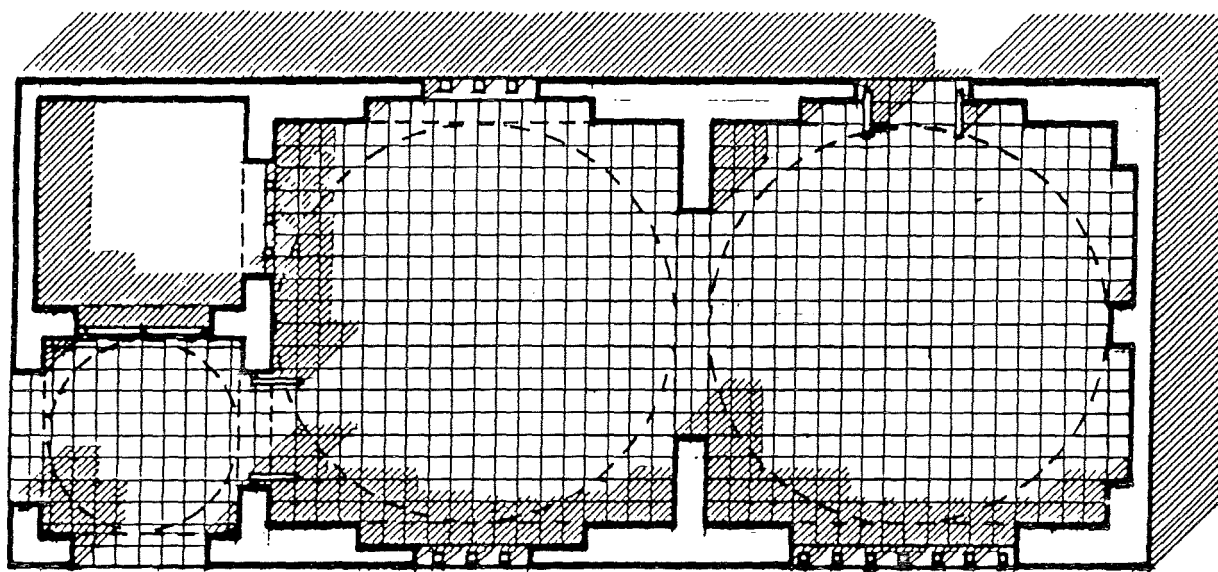
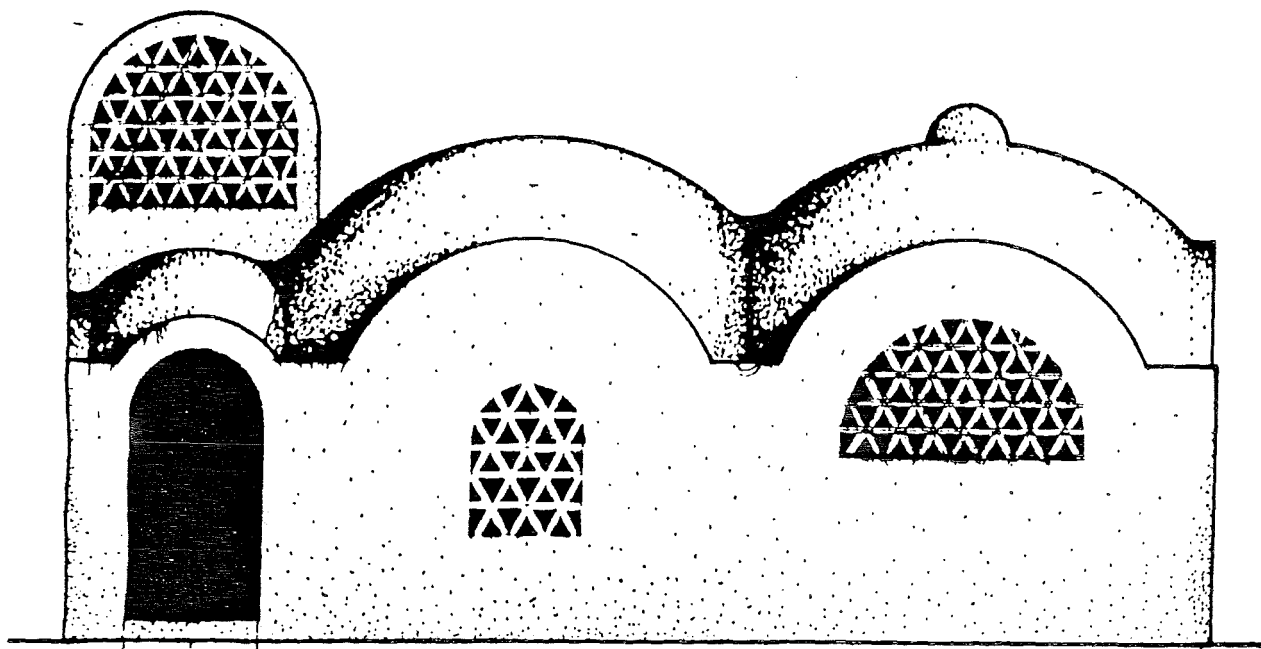

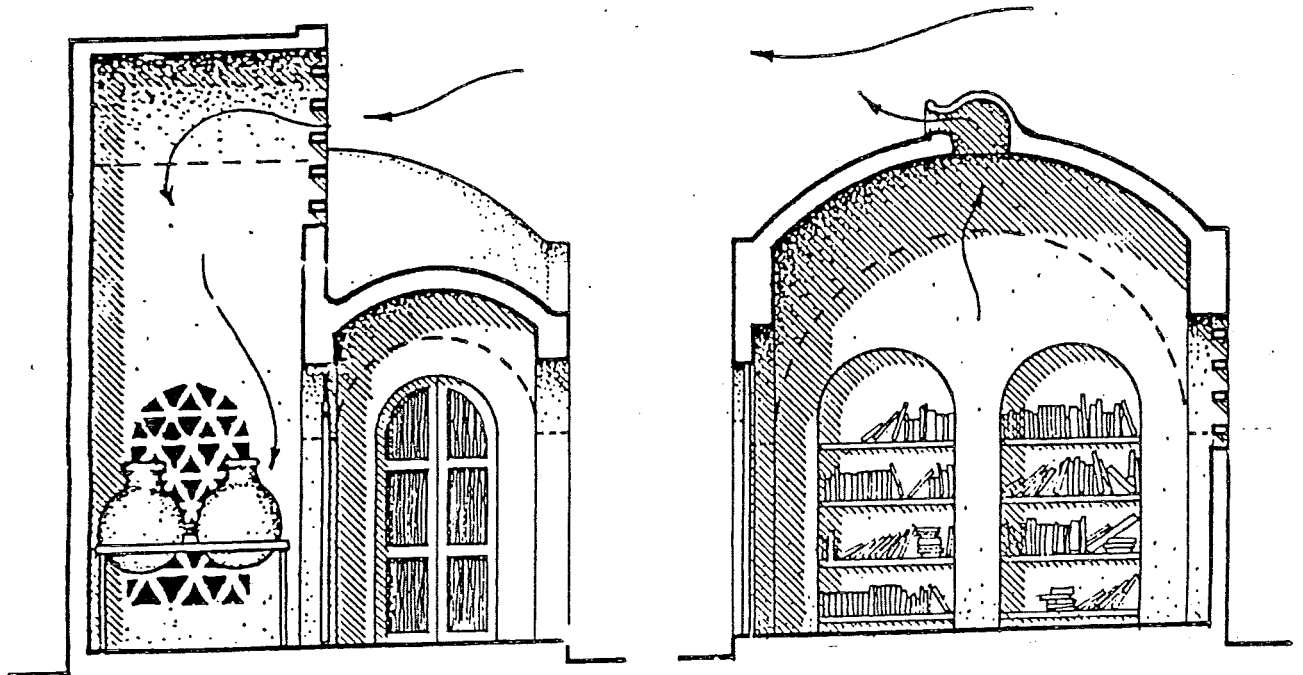
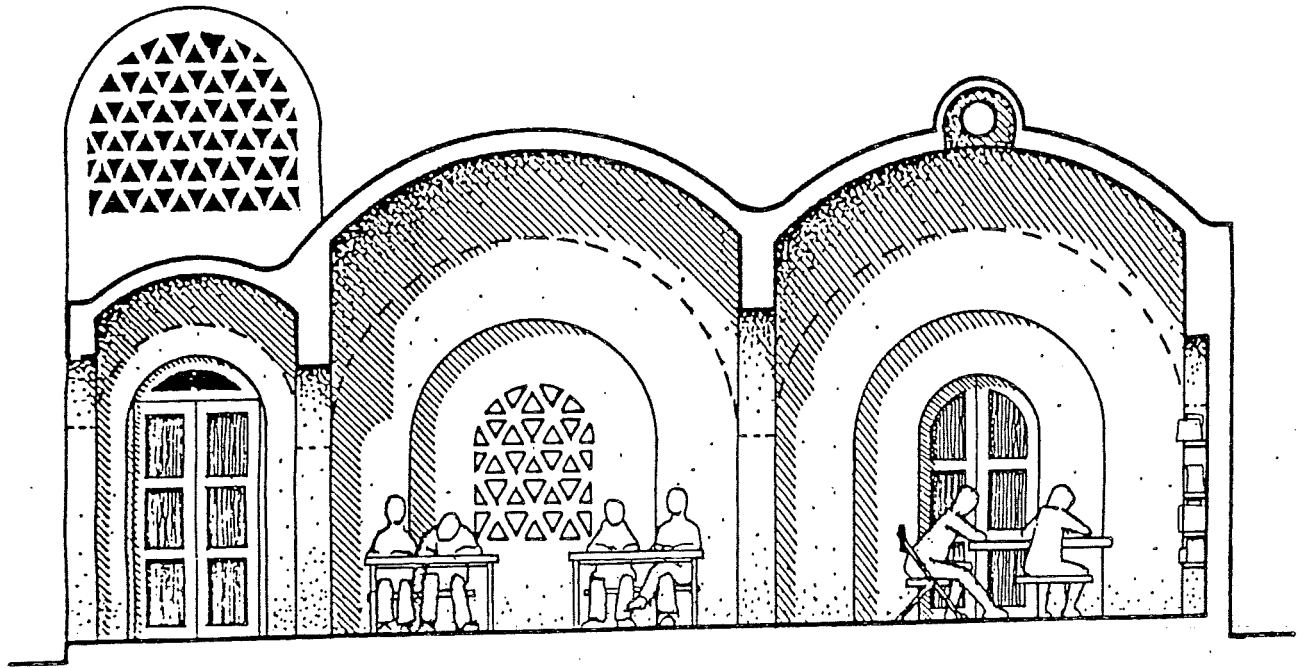

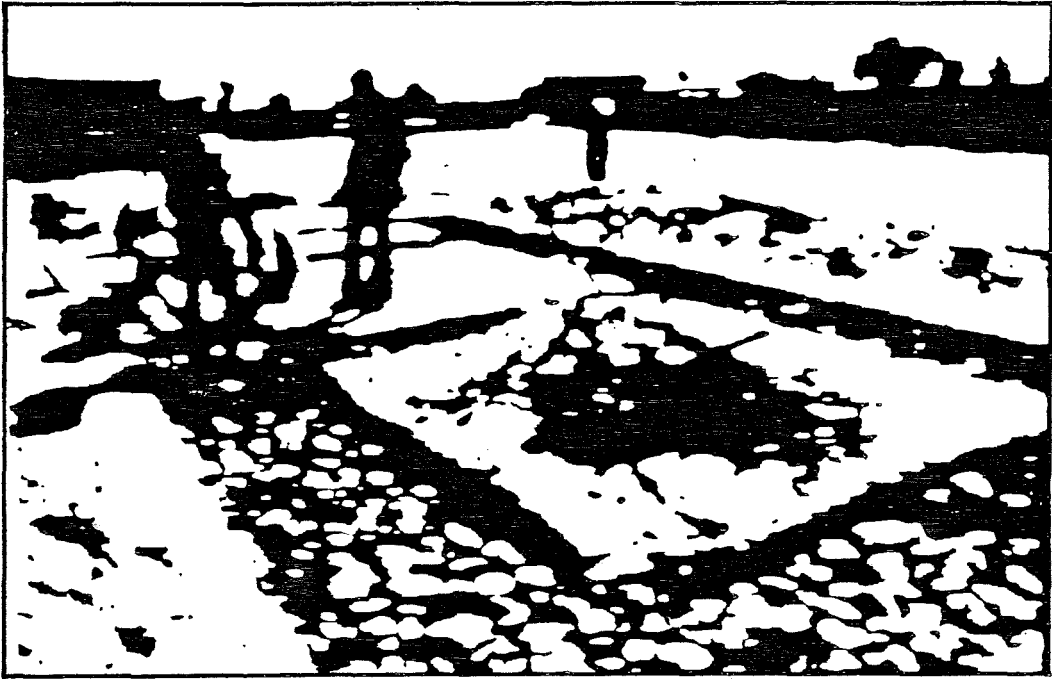

Footings were made of laterite rocks set in soil cement mortar. The base courses of the walls were soil cement blocks. Above this level the structure is completely of mud block and mud brick. Courses of mud block were laid uniformly so that the wall building of each part of the structure progressed at the same rate. This means that the masonry has time to dry sufficiently before more load is applied to it from further courses. About four courses a day could be laid in this manner. Because the Literacy Centre construction remained partly a training exercise the work organisation was adapted to give every trainee an opportunity to gain experience with each element. Thus work in some cases had to be dismantled and repeated where errors were made.





When the walls reached the spring point at 1.60 m the levels were checked very accurately. Arcs were built to form the bases for the domes. Builder trainees were divided into groups of two at this stage. This type of team work is essential from this stage on. In building arches, arcs, vaults and domes a builder working from each side of the structure is needed. Work must progress in a balanced way so that loads from one side or the other do not deform the structural shape.





Work proceeded at a slower pace at this stage. Care had to be taken to achieve the required level of precision needed to form a suitable base for the roof construction. Arch building proved to be the most difficult stage of the building process. Once properly completed dome building proceeded at a much more rapid pace, using the method described earlier incorporating a string anchored at the geometrical focus of the hemisphere. Two builders were able to complete the construction of a large dome in approximately two days.

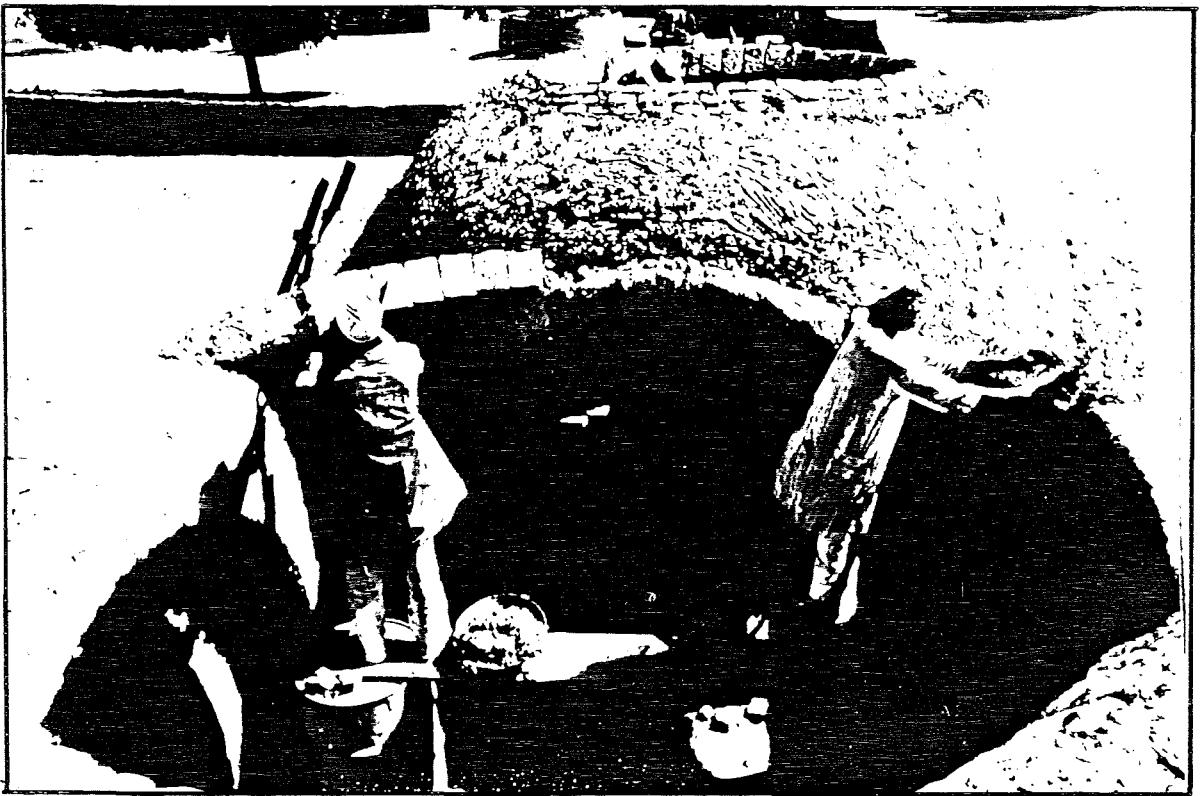
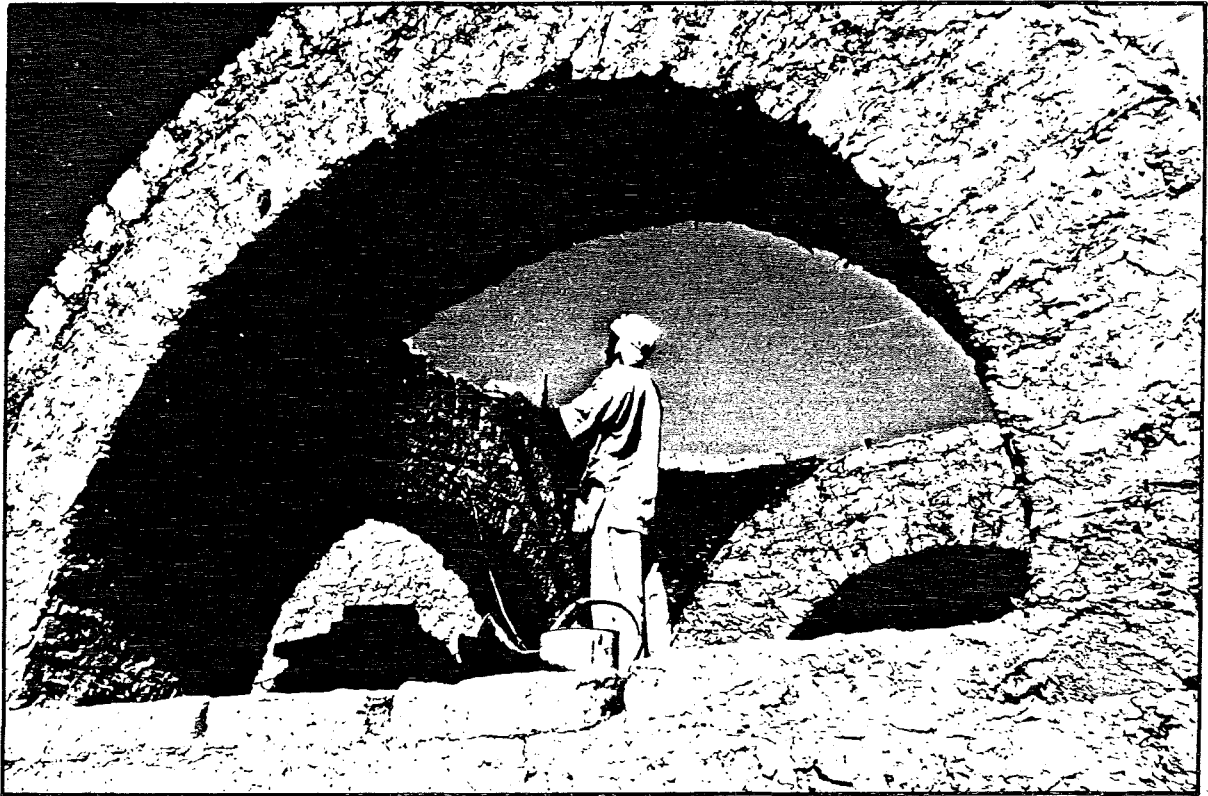



Finally the wind-catcher was build incorporating a vault over the air shaft. As previously explained vault construction does not depend on geometrical aids and requires a practiced eye to keep the structure in alignment. Because the wind-catcher vault was located at the highest point of the building, the vault builder did not have the opportunity to step back to visually line up their work. For this reason the vault had to be built several times in order to perfect the form.

A simple method of triangular lattice work was demonstrated which the builders were able to master with a little practice.

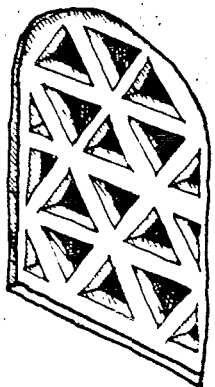

Brick claustrum work  
is an effective way  
of providing shade and  
reducing glare cheaply.  
Can be accurately designed  
to meet local shading needs.





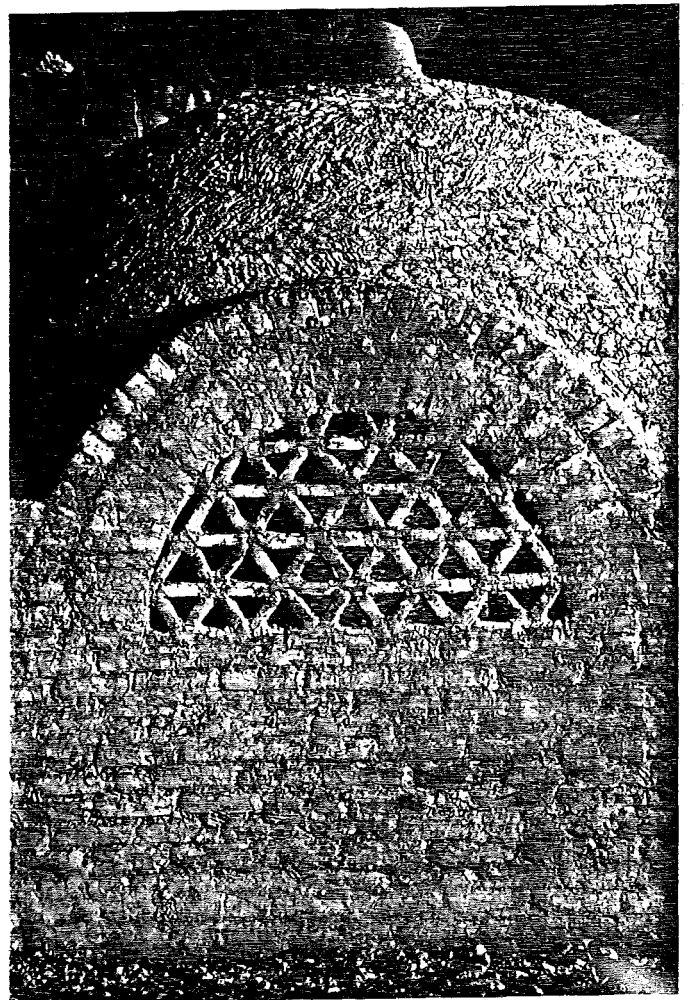
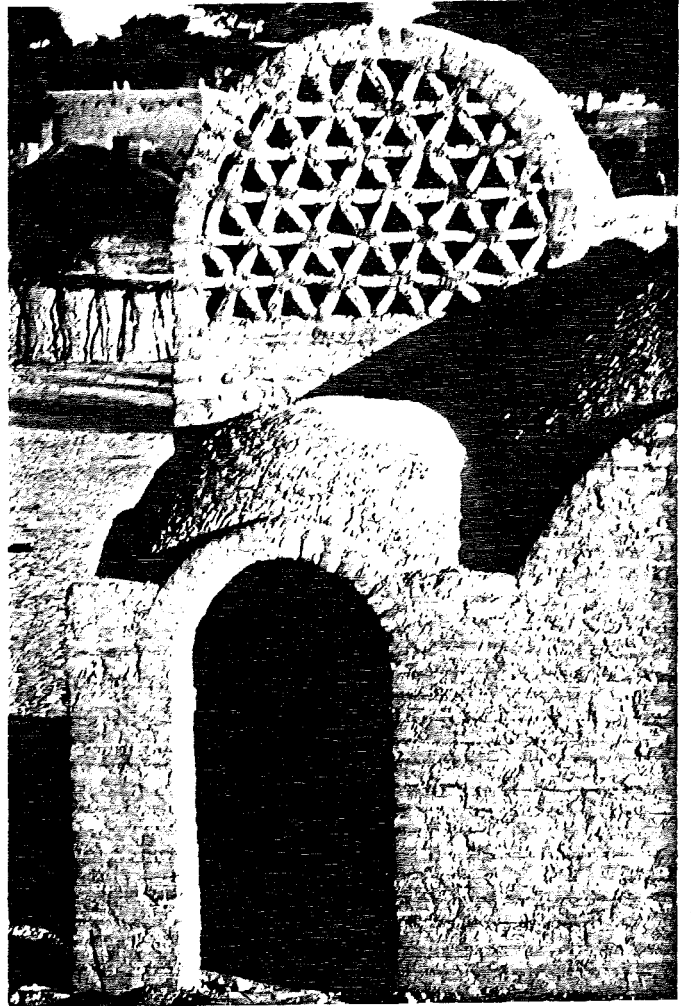

### Finishes and Hardware

1. It was recommended that the exterior walls be rendered with either the acacia render or a soil cement mixture. The Literacy Centre could be used to test the potentials of the acacia render over a period of several years.
2. It was recommended that a charcoal filter and evaporative cooling system be installed in the base of the wind catcher. The charcoal system is advisable to filter out unwanted dust. Single unglazed water pots can be used as a second option to provide evaporative cooling, though without the filtering action.
3. A simple hinge system was developed to eliminate the need for wooden door and window frames (which are normally eaten away by termites in a short time). One flange of the iron hinge is bolted to the door or window and the other is anchored into the mud wall. The door, even if made of wood is therefore completely isolated from the mud walls or floor and hence from possible termite penetration.

Two example hinges were made to our specifications by the Chikal blacksmith with a small hand forge fired by a few small pieces of charcoal.

It was recommended that the hinges be fixed to window shutters or windows to be located on the interior side of the lattice screens.

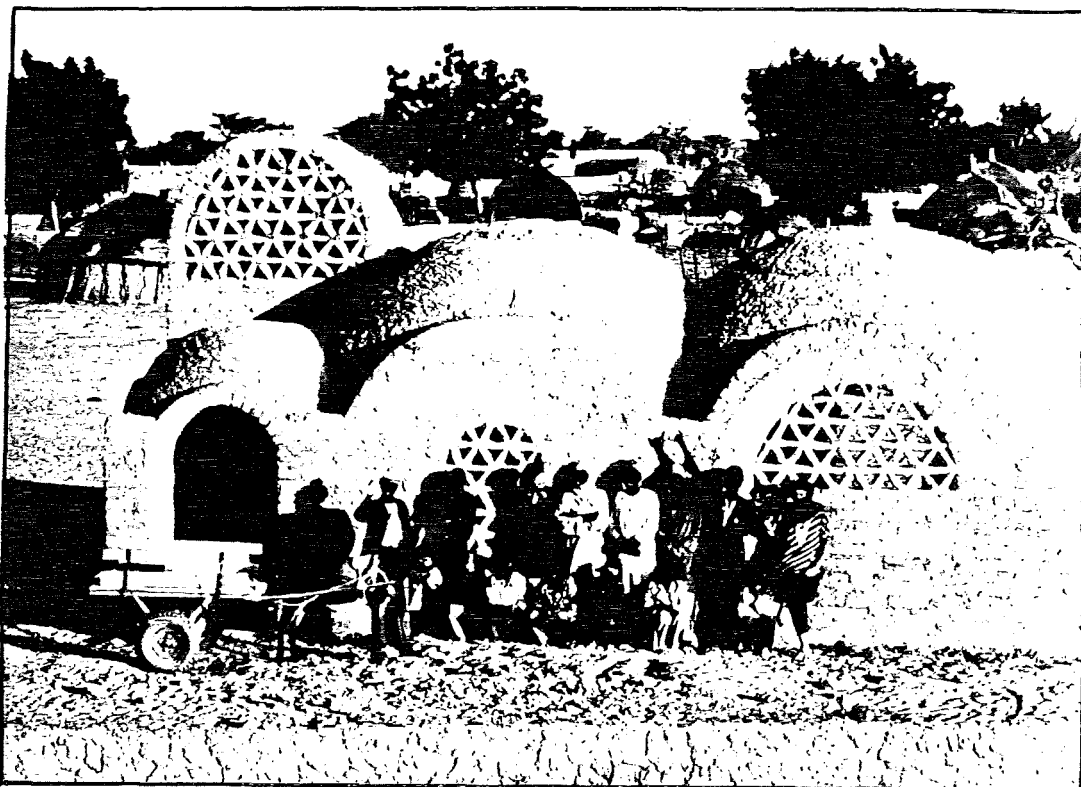

### Conclusion

An evaluation of the builders' skills at the end of the workshop and pilot building project indicated that while they had made considerable progress in a very short period, supervision of their work should be maintained for some time into the future.

Further pilot projects should be carried out under supervision on projects carefully planned to demonstrate further possibilities of the vault and dome system.

Further training should be carried out to introduce further refinements to the vault and dome system, develop technical skills such as plan reading, basic vault and dome design principles, and to consolidate previous experience. The aim should be to equip the building team to operate independently and have sufficient command of the system to adapt it to their own communities' needs.

# Development Workshop

on Building & Planning in the Third World

Box 133  
238 Davenport Road  
Toronto  
Ontario M5R 1J6  
Canada

Report following visit by John Norton  
to the Projet Tapis Vert, August 1982

REPORT FOLLOWING VISIT TO CHIKAL, PROJECT TAPIS VERT BY JOHN NORTON

AUGUST 1982

In order to evaluate the results of the original training and building programme done by Allan Cain in December 1980 for the Project Tapis Vert, Development Workshop arranged to send John Norton on their behalf to Chikal in August 1982.

Arrangements for the duration of his stay in Niger were kindly looked after by the Project Tapis Vert staff, whom we would like to thank.

EVALUATION

The Literacy Centre

The Literacy Centre has had little maintainance except for the recent application of a sand cement render to the outside of the roof and to the east facing wall which is exposed to the prevailing rain bearing winds. We are pleased that the building is in good condition and appears to be getting good use.

There have been several modifications to the building and to its surroundings, notably the addition of a courtyard perimeter enclosure to the north of the building (see site plan) with a pit latrine in the north east corner and a number of 'chulna' type cooking stove experiments along the west wall of this courtyard.

The original brick lattice screening in the window openings have been replaced by metal louvre shutters which are the commonest commercially available type. This seems a reasonable expedient solution. We would note that the original design for window and door fittings would have been made by the local village blacksmith but had not been followed through.

The windcatch opening has been recently closed and the small outlet in the dome over the library room has been blocked during the rains. It is worth observing that the necessary filtration system (see detail in original drawings) to keep dust from blowing through the windcatcher had not been incorporated and that in this case the decision to close the windcatch intake is logical. The base of the windcatch shaft is at present being used for storage. We hope that time will be found at a later date to complete

/the